

TUBE•LINE™

Tubeline Manufacturing Limited
6455 Reid Woods Drive RR #4
Elmira, Ontario, Canada N3B 2Z3

Email: sales@tubeline.ca

Fax: 519.669.5808

Tel: 519.669.9488

Toll-free (North America): 1.888.856.6613

www.tubeline.ca

Operator's Manual

Keep this manual with the machine at all times.

ACCELERATOR **HAY CONDITIONER**

Accelerator Hay Conditioner

HC7500 / HC9500

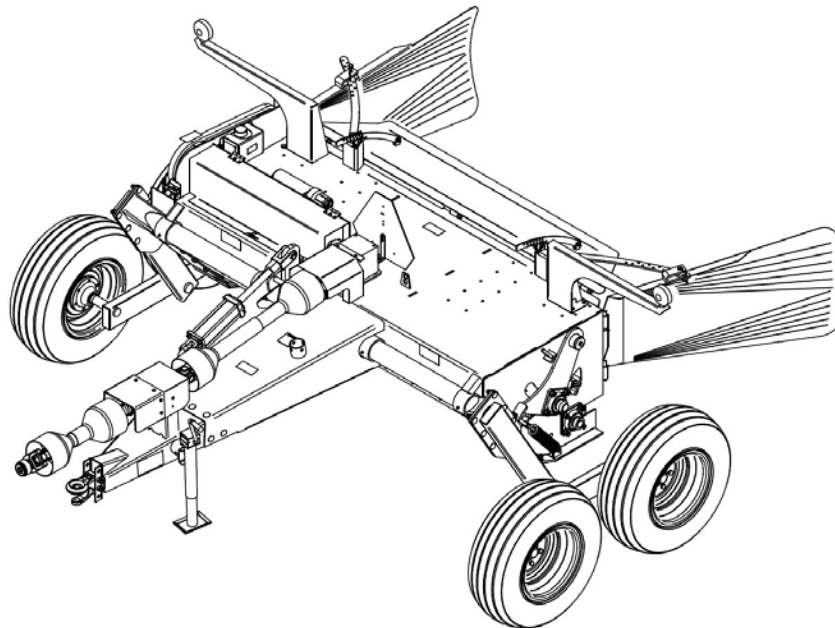

Operator's Manual

Thank you for choosing the Tubeline Accelerator Hay Conditioner. We know it will give you many years of productive service.

The Tubeline Accelerator has been developed to quicken the drying process of cut foilage by squeezing moisture and cracking hay stems rapidly between two rollers and evenly returning it back into windrows. There should be no loss of nutrients as hay leaves are not removed with this machine. Conditioning also fluffs the hay, allowing air to flow through the swath, for faster and more even drying from top to bottom.

Functionality as a tedder is added with an optional spinner kit.

Improvements

Tubeline Manufacturing Inc. is continually striving to improve its products. We reserve the right to make improvements or changes when it becomes practical and possible to do so, without incurring any obligation to make changes or additions to the equipment sold previously.

Please read and understand this manual and the machine before operation. Newer manual version can be found at www.tubeline.ca/support

Warranty and Limitation of Liability

All equipment is sold subject to mutual agreement that it is warranted by the company to be free from defects of materials and workmanship. But the company shall not be liable for special, indirect or consequential, damages of any kind under this contract or otherwise. The company's liability shall be limited exclusively to replacing or repairing without charge, at its factory or elsewhere, at its discretion.

Any material, or workmanship defects which become apparent within one year from the date on which the equipment was purchased, and the company shall have no liability for damages of any kind. The buyer by the acceptance of the equipment will assume all liability for any damages, which may result from the use or misuse by his employees or others.

Serial Number

The implement serial number is located on the front of the frame. This number helps us to track changes and improvements and must be mentioned when ordering parts or requesting service. For your convenience, a space has been provided inside the front cover of this manual to record the serial number, model number, purchase date, and dealer name.

Model No: _____ HC7500T or HC9500T

Serial No: _____

Date Purchased: _____

Dealer Name: _____

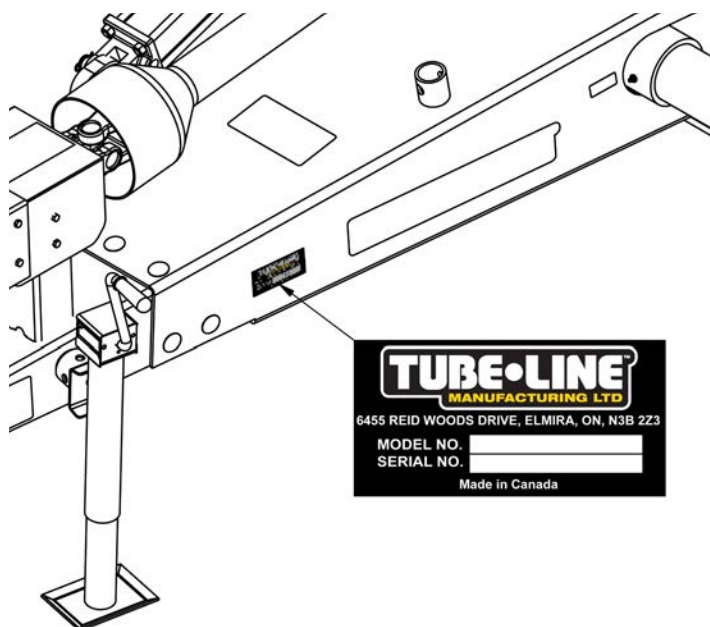

Table of Contents

Operator's Manual	I
Improvements	I
Warranty and Limitation of Liability	I
Serial Number	I
Section 1: General Information	1-1
Terminology : Accelerator	1-1
Principle Components	1-1
Terminology : Accelerator Locations	1-1
Accelerator Initial Setup	1-2
Specifications	1-3
Tractor Requirements	1-4
Tire Ratings	1-4
Section 2: Safety	2-1
Safety Signal Words / Safety Messages	2-1
Safety Guidelines	2-1
Maintenance Safety	2-2
Hydraulic Safety	2-2
Tire Safety	2-3
Transport Safety	2-3
Safety Signs	2-3
ISO Safety Decal Locations	2-4
ISO Safety Decals	2-5
Model Decal Locations	2-6
Model Decals	2-7
Section 3: Transportation	3-1
Accelerator Hook up to Power Unit	3-1
Transport Lock	3-2
Section 4: Adjustments	4-1
Deflectors	4-1
Roller Tensioning - Up to SN 22HCT101	4-1
Roller Tensioning - SN 22HCT101 to Current	4-2
Roller Chain Tensioning	4-3
Section 5: Operation	5-1
Section 5: Lubrication	5-1
Grease Points	5-1
Grease Point - PTO Knuckles	5-1
Grease Point - Lifting Pivot	5-2
Grease Point - Pillow Block Bearing	5-2
Section 6: Maintenance	6-1
Friction Clutch Maintenance	6-1
Daily Maintenance	6-2
Preseason Service	6-2
End of Season Service	6-2
Section 7: Troubleshooting	7-1

Section 8: Parts Breakdowns & Lists	8-1
Main Frame Components	8-2
Rollers	8-4
Driveline	8-6
Discharge Shields	8-8
Left Side Panel	8-10
Right Side Shields	8-12
Right Side Chain	8-14
Rosta Tensioner - Chain Oiler	8-16
Hydraulic Layout	8-18
Section 9: Driveshafts	9-1
PP00338 - Slip Clutch Drive Shaft	9-1
PP-00339 - PTO Drive Shaft	9-2
PP00836 - HC7500 Cross Drive Shaft	9-3
PP00837 - HC9500 Cross Drive Shaft	9-4
Section 10: Options	10-1
HCSK7500T - Spinner Kit	10-1
Spinner Kit Terminology	10-1
Spinner Kit Components	10-1
HCSK7500T - Spinner Kit Installation	10-2
Spinner Kit Setup	10-3
Spinner Adjustment	10-3
Spinner Operation	10-3
Spinner Kit Grease Points	10-4
Spinner Kit Maintenance	10-4
Spinner Kit Troubleshooting	10-4
HCSK7500T - Spinner Kit	10-5
HCSK7500T Spinner Kit - Hydraulic Layout	10-7
HCLK7500 / HCLK9500 - Light Kit	10-8
Torque Values - Imperial	IV
Torque Values - Metric	V

Section 1: General Information

Terminology : Accelerator

The Tubeline Accelerator consists of two rollers located on the underside of the machine. The Accelerator is powered by the PTO driveline and hydraulic pressure from the tractor.

Principle Components

1. Lift cylinder
2. PTO driveline
3. Gear box
4. Rollers
5. Deflectors
6. Light arms

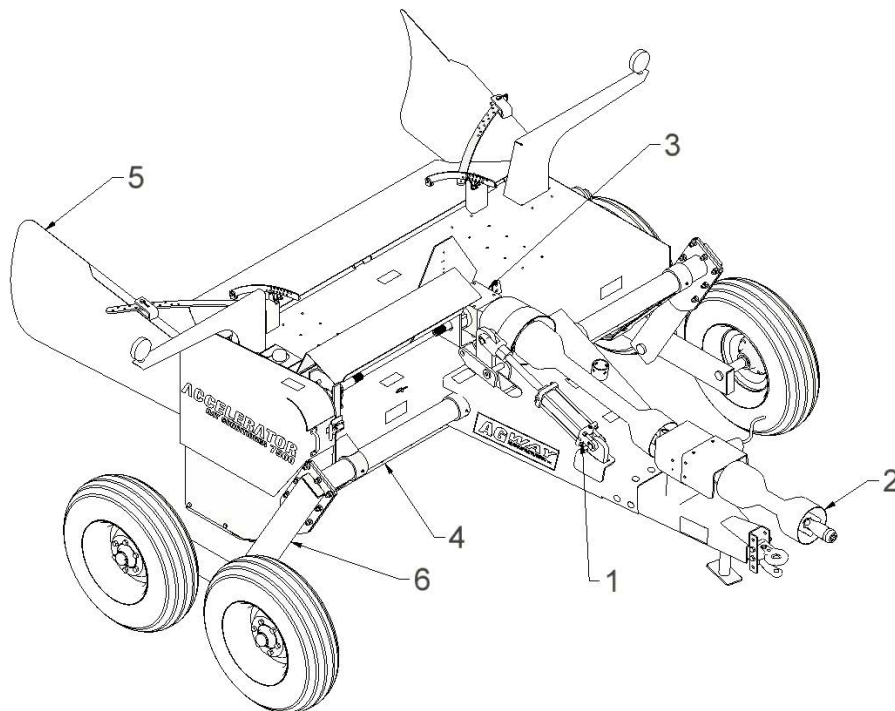

Terminology : Accelerator Locations

- Front
- Rear
- Left
- Right
- Hook up
- Ejection area

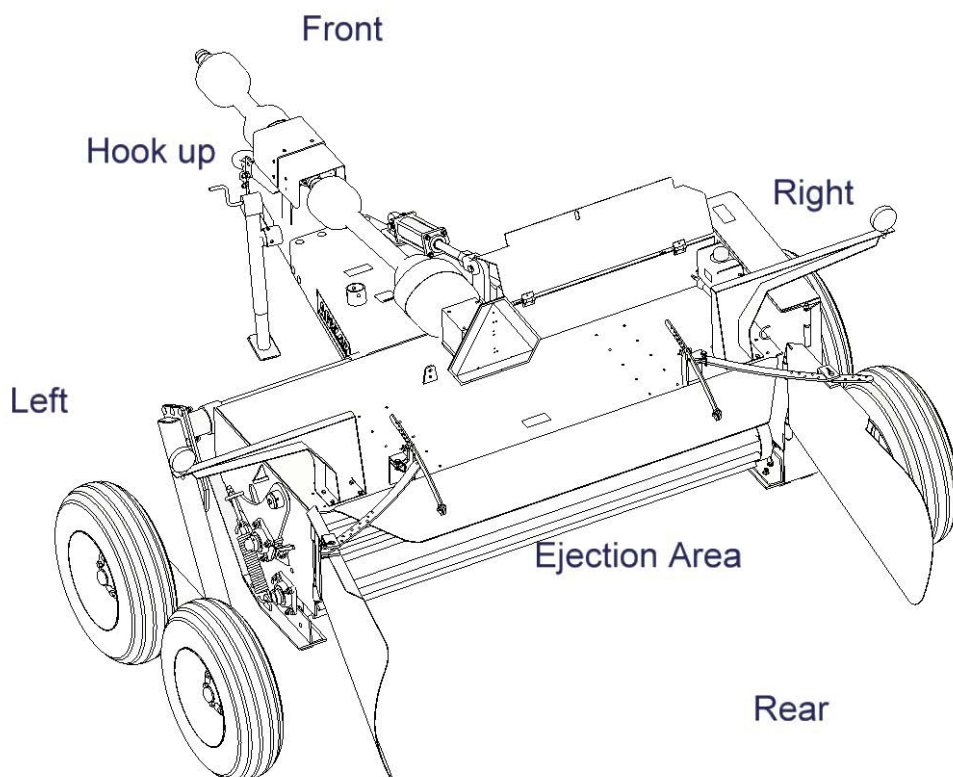

Accelerator Initial Setup

The Tubeline Accelerator in most cases will come assembled and ready to operate, however customers outside of North America may receive the Accelerator in a crate and will require some assembly.

Note: Tandem axles must be installed with short side towards front.

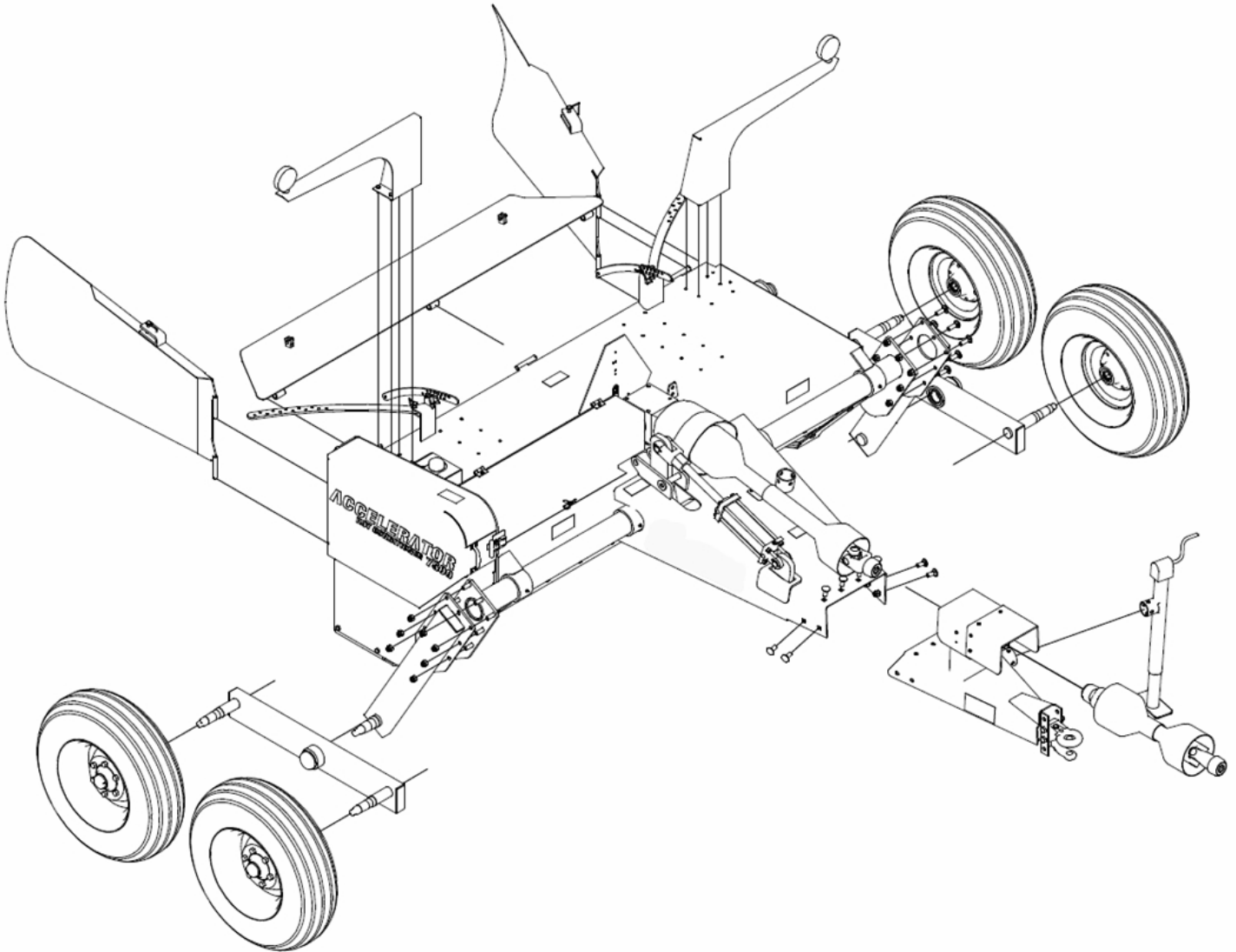

Specifications

**HC7500 shown*

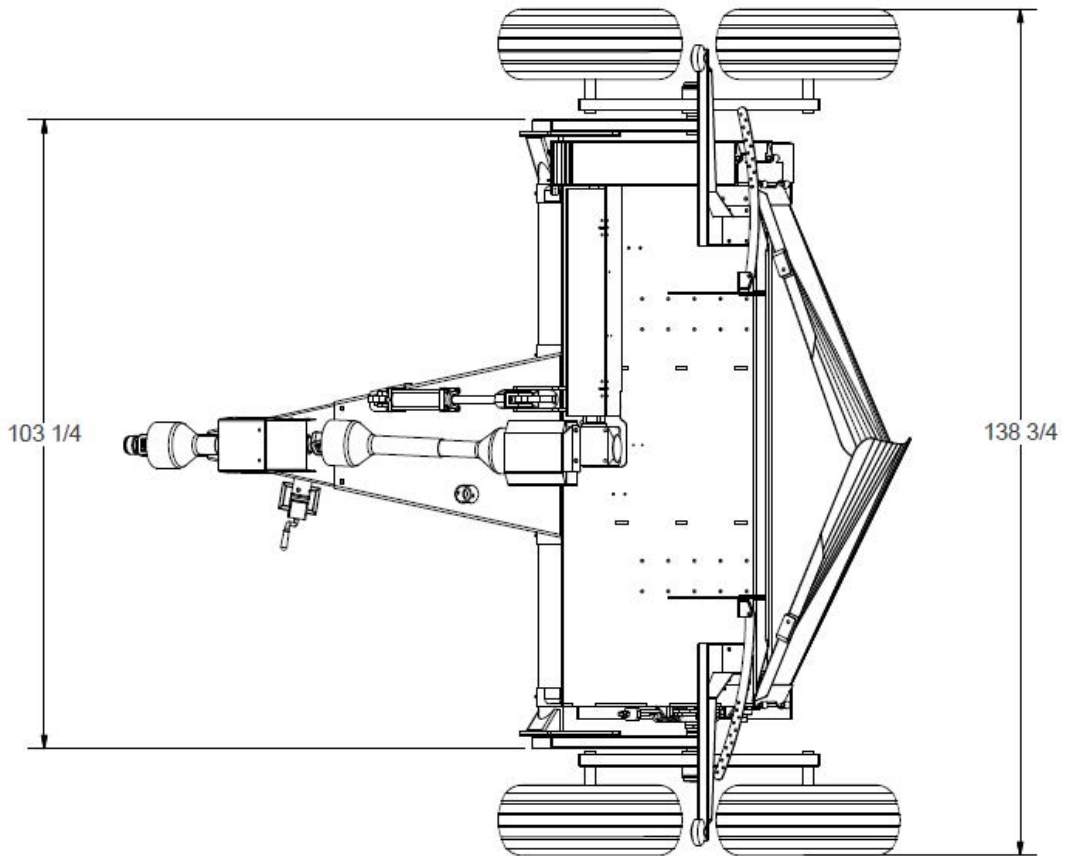

**HC9500 shown*

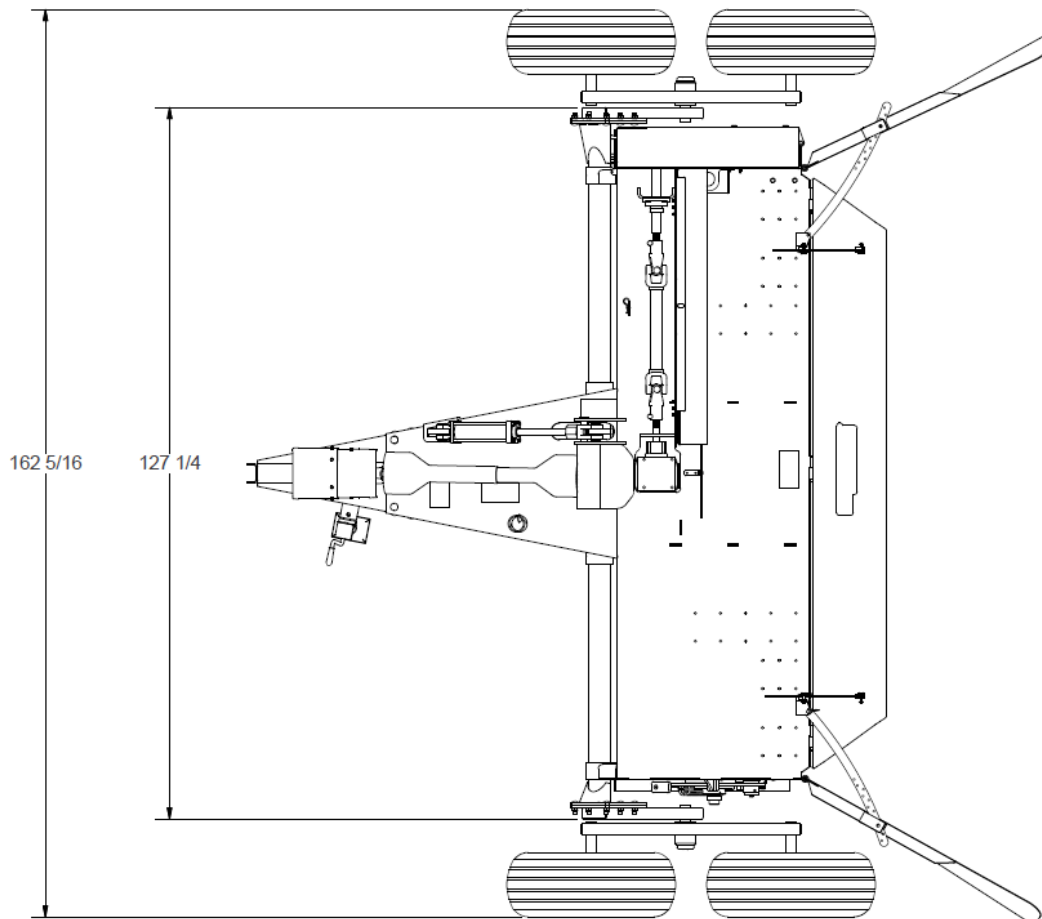

*Side dimensions are same for HC7500 and HC9500

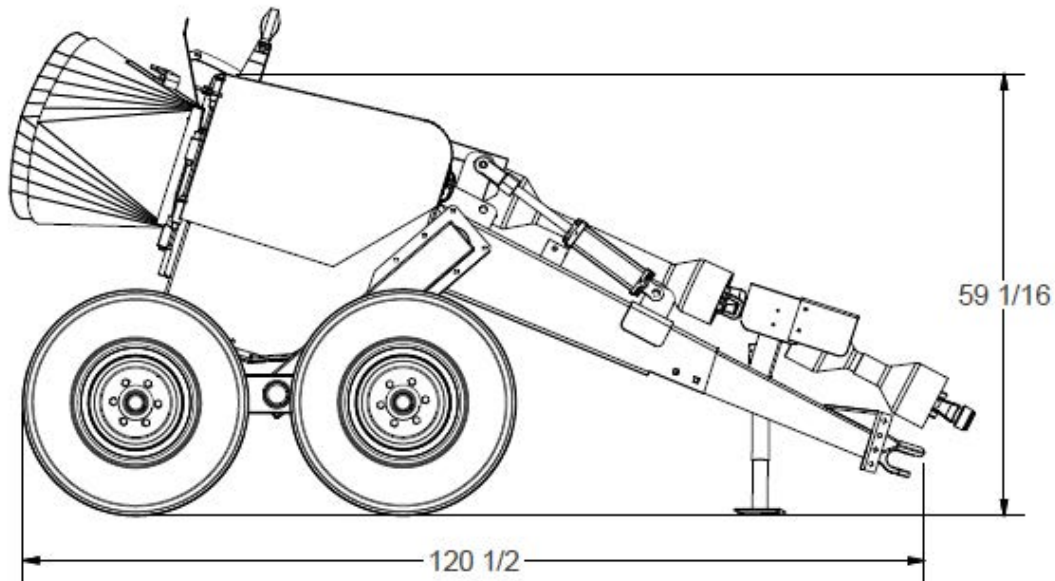
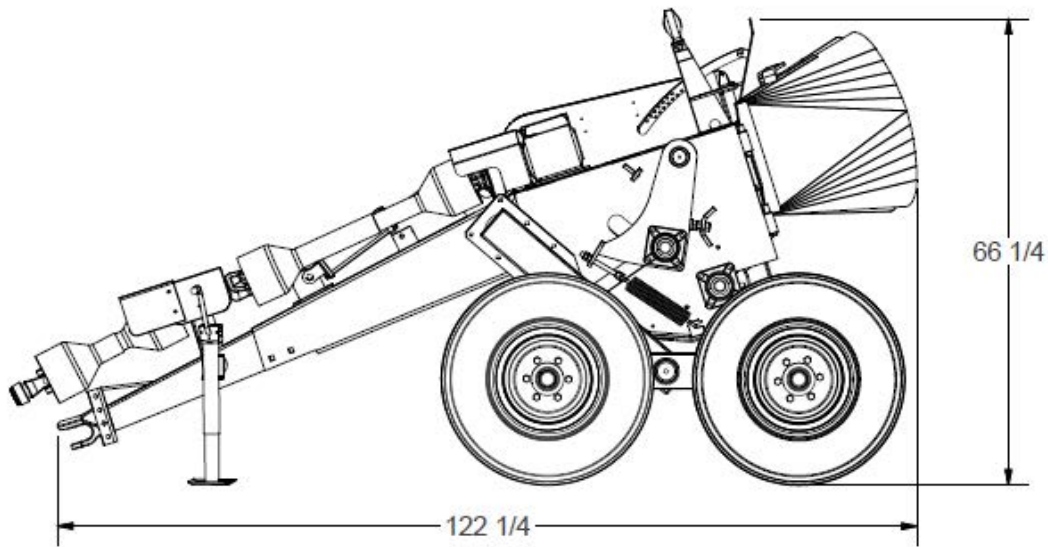

Tractor Requirements

To operate the Tubeline Accelerator requires a tractor with minimum 60HP.

Tire Ratings

Replacement tires must meet or exceed these ratings while matching the dimensions.

SIZE	LOAD RANGE	DIAMETER	WIDTH	RIM WIDTH	MAX CAPACITY	PSI	TREAD DEPTH	SPEED RATING
11L-15	8 Ply	30.5"	11"	15"	2540lbs	36	10/32nds	25mph

Section 2: Safety

NOTE: This safety alert symbol is found throughout this manual to call attention to instructions involving yourself and others working around the machine. Failure to follow these instructions can result in injury or death!



This symbol means

Attention!

Become Alert!

Your Safety is involved!

Safety Signal Words / Safety Messages

CAUTION: Indicates a potentially hazardous situation that may result in injury.

WARNING: Indicates a potentially hazardous situation that could result in serious injury or death.

DANGER: Indicates a hazardous situation that needs to be avoided. Operator needs to be aware of these dangers. High probability of serious injury or death.

NOTE: Indicates an informative non-safety related message.

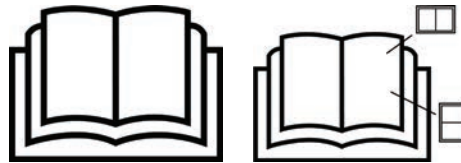

Safety Guidelines

Safety of the operator is a main concern, take necessary precautions while operating and maintaining this machine. To avoid personal injury study the following precautions and insist those working with you or for you, follow them.

Do not allow anyone to operate the Accelerator who has not been instructed in how to use the machine.

All operators should familiarize themselves with the safety section in the operator's manual. Review the safety instructions with all users annually.

This equipment must not be operated by children.

This manual may show machine with shields removed, this is only to show a view behind the shield. Keep all the shields and safety doors in place. If they become faulty and fail to work replace them.

Do not operate this machine while under the influence of drugs or alcohol.

Keep a first aid kit in the cab for emergencies and know how to use it.

When transporting the machine on public roads, make sure the machine is in compliance with all local road regulation.

Before operating the unit be sure that it is assembled correctly and in good operating condition.

Before leaving the cab, engage the parking brake, shut down engine, and wait for all moving parts to stop.

Do not allow any one to ride on the Accelerator while it is in motion.

Clear the area of bystanders, especially small children before starting the Accelerator.

Always keep bystanders away from machine during operation, Rotating elements may cause serious bodily injury.

Maintenance Safety

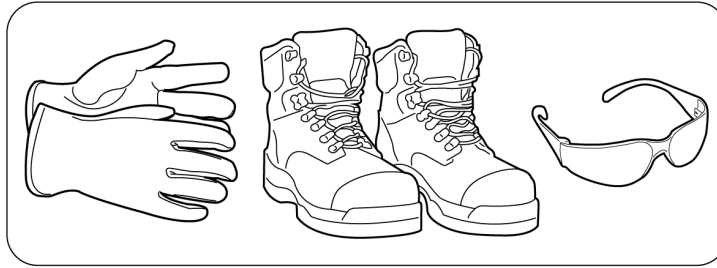

If machine maintenance work, repairs or adjustments must be done in the field, they should be done at a spot where the ground is firm and level. Turn off the tractor and apply the parking brake. Use the proper tools and wear suitable protection (safety goggles, work gloves, etc.).

If any maintenance work, repairs or adjustments are done which require disassembly, always make sure that everything is reassembled or retightened as it has been prior to making repairs or adjustments.

Follow the schedule provided for maintenance. By following these suggestions, it will be possible to keep the machine operating safely and efficiently, to the benefit of the user.

DO NOT remove side guard until all moving parts have stopped, rollers and chain inside the side panel are free wheeling and may be still spinning, failure to comply could result in death or serious injury.

Replace any shields removed for repairs or maintenance before operating this machine.

Do not paint over, remove or deface any safety signs or warning decals on your equipment. Observe all safety signs and practice the instructions on them.

Replace any decals that may be missing or that are not readable. Location of the decals is indicated in this manual, [pg.2-4](#).

Hydraulic Safety

Before applying pressure to the system, be sure all connections are tight and that hoses and connections are not damaged.

Ensure that all the pressure is released from the hydraulic lines before repairing. Replace or repair damaged hoses immediately.



WARNING

When checking for oil leaks use a piece of cardboard; **DO NOT** use your hand:

- Escaping fluid under pressure can penetrate the skin causing serious injury.
- Avoid the hazard by relieving pressure before disconnecting hydraulic of other lines.
- Tighten all line connections before applying pressure.
- Protect hands and body from high-pressure fluids.

If an accident occurs, see a doctor immediately. Any fluid injected into the skin must be surgically removed within a few hours or gangrene may result. Failure to comply could result in serious injury, paralysis or even death.

Tire Safety

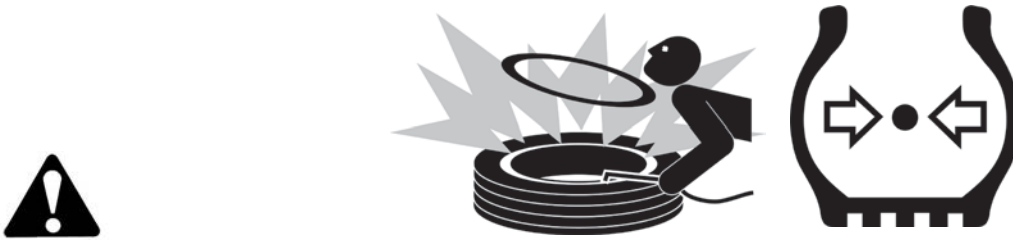

DANGER: Failure to follow proper mounting procedures when mounting a tire on a wheel or rim can produce an explosion which may result in serious injury or death.

- Do not attempt to mount a tire unless you have the proper equipment and experience to do the job.
- Have a qualified tire dealer or repair service perform required tire maintenance.
- When replacing worn tires, make sure they meet the original tire specifications.

NOTE: Proper tire pressure and maximum load details can be found in [Tire Load Ratings, pg. 1-4](#).

Transport Safety

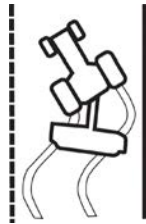

Transport the Tube-line Accumulator with an SMV (Slow Moving Vehicle) sign, displayed at the rear of the Accumulator and use your hazard lights if the law permits. Check local road laws before transporting.

1. When transporting the Accumulator on the road be aware of the width, and length of the machine.
2. Do not transport the machine, at night, at dawn, or at dusk.
3. Do not exceed 32kph (20mph) during transport.

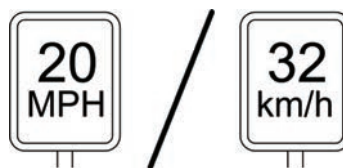

Safety Signs

1. Keep safety signs clean and legible at all times.
2. Replace safety signs that are missing or have become illegible.
3. Replaced parts that displayed a safety sign should also display the current sign.
4. Safety signs displayed in Safety Sign Locations each have a significant purpose and need to be cleaned or replaced when necessary.
5. Safety signs are available from your authorized distributor or dealer parts department or from the manufacturer.

ISO Safety Decal Locations

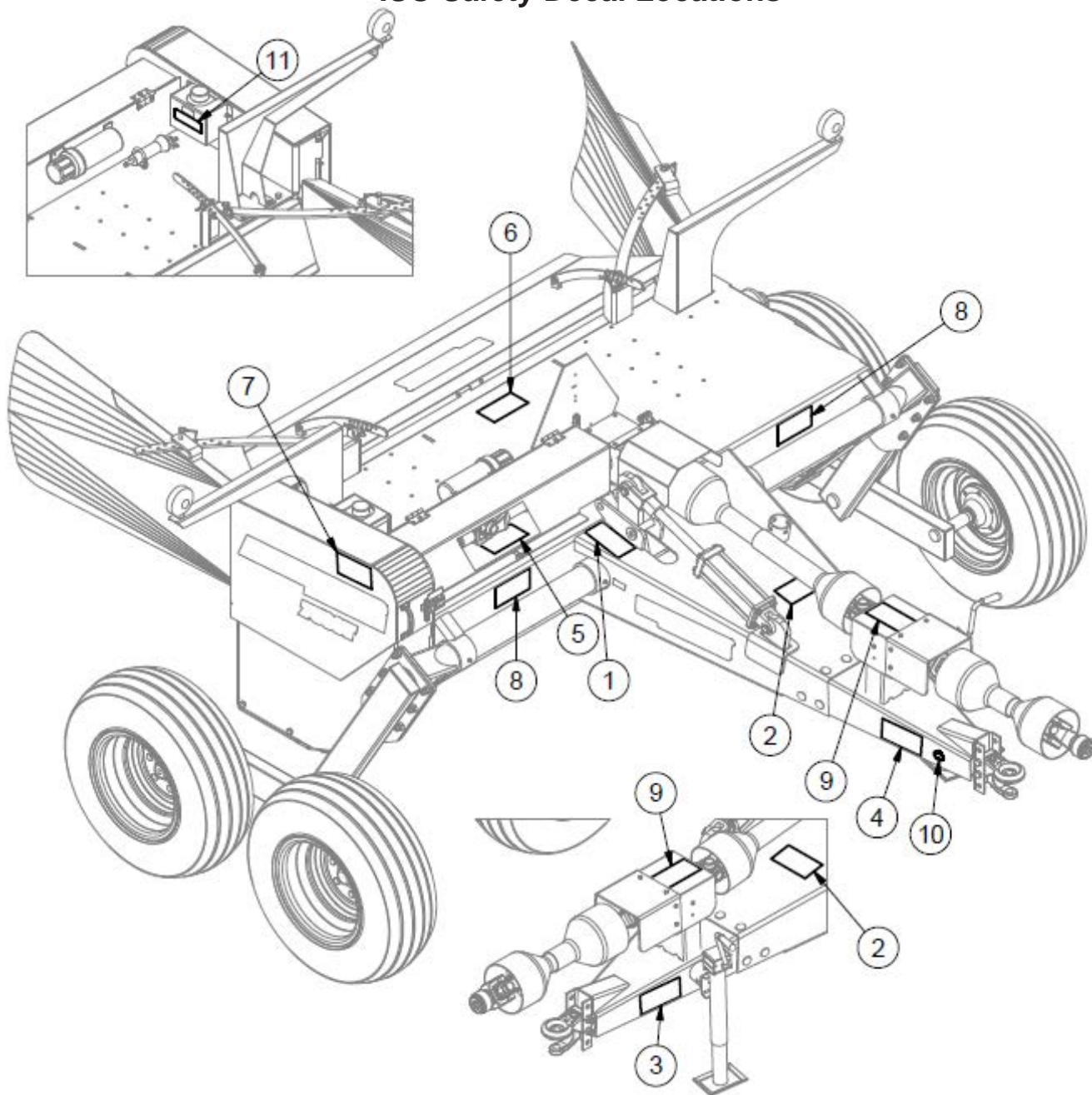

ITEM	QTY	PART NUMBER	DESCRIPTION
	15	DE23979	Grease Decal
1	1	DE41712	ISO Decal - Hand Pinch Point
2	1	DE41713H	ISO Decal - High Pressure Fluid Horizontal
3	1	DE41714H	ISO Decal - Read OM Horizontal
4	1	DE41715H	ISO Decal - Remove Key Before Repair Horizontal
5	1	DE41716H	ISO Decal - Shaft Entanglement Horizontal
6	1	DE41718H	ISO Decal - Thrown Object Horizontal
7	2	DE41902	ISO Decal - Chain Entanglement
8	2	DE42537	ISO Decal Roller Entanglement
9	1	DE42785	ISO Decal - PTO Entanglement
10	1	DECANADA	Decal Made In Canada
11	1	DEPP00929	Important Use SAE #30 Oil 2" x 6.5" Decal

ISO Safety Decals



Item 1: DE41712
Hand pinch point hazard.
Keep hands clear of cylinder
stop while operating.

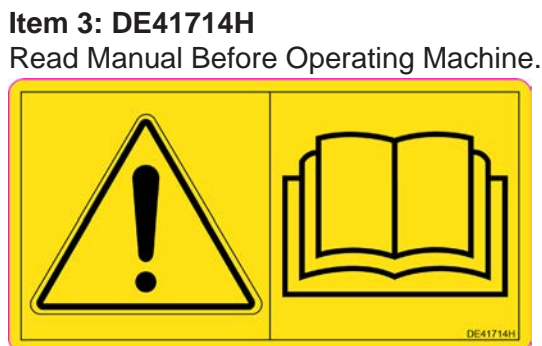

Item 3: DE41714H
Read Manual Before Operating Machine.

Item 2: DE41713H
Hydraulic pressure puncture hazard.
Read manual maintenance section
before repairing.



Item 4: DE41715H
Remove key from power
unit and read manual
maintenance section
before attempting repairs.

Item 5: DE41716H
Shaft entanglement hazard.
Keep hands away from moving shaft
and do not operate machine without
shields in place.



Item 6: DE41718H
Thrown object hazard.
Be sure all observers
are clear of discharge
area while operating.

Item 7: DE41902
Chain entanglement hazard.
Keep hands clear and shields in place
while operating machine.

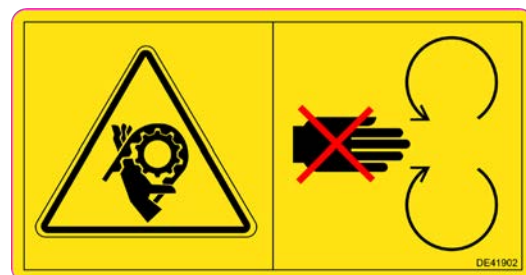

Item 8: DE42537
Roller entanglement hazard.
Do not attempt to dislodge material from
spinning rollers. Entanglement could
cause paralysis or death.



Item 9: DE42785
PTO entanglement hazard.
Stand clear of PTO drivelines
while operating. Entanglement
could cause paralysis or death.



Item 10: DECANADA
This product is
proudly manufactured
in Canada.

Item 11: DEPP00929
Use clean SAE #30 oil for chain
auto greaser. See Lubrication
section for further information.



Model Decal Locations

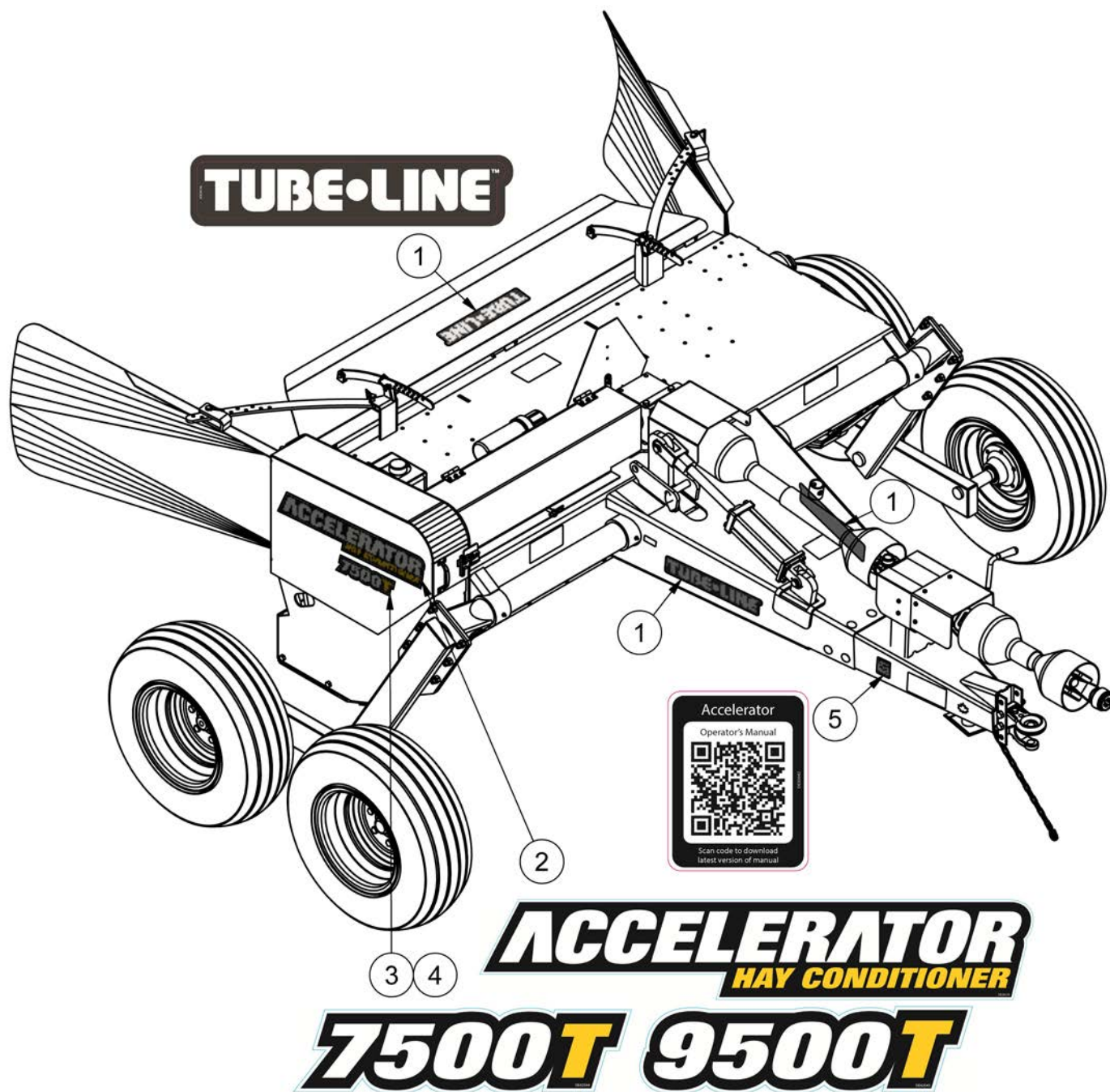

ITEM	QTY	PART NUMBER	DESCRIPTION
1	3	DE28146	Tubeline Decal 4" x 16"
2	1	DE28714	Hay Conditioner Accelerator 5.5" x 30.0" Decal
3	1	DE42544	HC7500T Model Decal
4	1	DE42545	HC9500T Model Decal 3" x 12"
5	1	DE50042	Accelerator QR Decal

Model Decals



Item 1: DE28146
Tubeline logo decal.



Item 2: DE28174
Accelerator Hay
Conditioner
decal.



Item 3: DE42544
HC7500T model decal.



Item 4: DE42545
HC9500T model decal.



Item 5: DE50042
Accelerator QR code, scan with
smartphone to access manual..

Section 3: Transportation

Accelerator Hook up to Power Unit

1. Remove hitch (2), 5/8-11 x 4.5" bolts (3) and nuts from the accelerator.
2. Attach the loose hitch on the Accelerator to the draw bar of the tractor with a draw pin.
3. Attach the PTO driveline (1) to the tractor.
4. Adjust height of accelerator with jack (5), until the PTO driveline is in line with the power unit's PTO outlet shaft.
5. Reattach hitch to the Accelerator hitch plate at best aligned holes to assure PTO stays aligned.
6. Remove jack bolt, turning jack 90° and refastening bolt to lock jack into horizontal position.

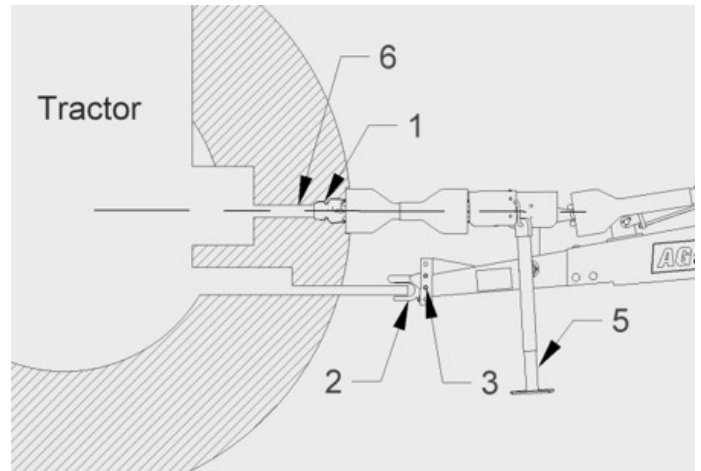

NOTE: Set the Accelerator so that the hitch point to the PTO stub shaft is the same distance as the distance from the hitch point to the tractor's PTO output shaft, approximately 16".

7. Latch safety chain to tractor frame.

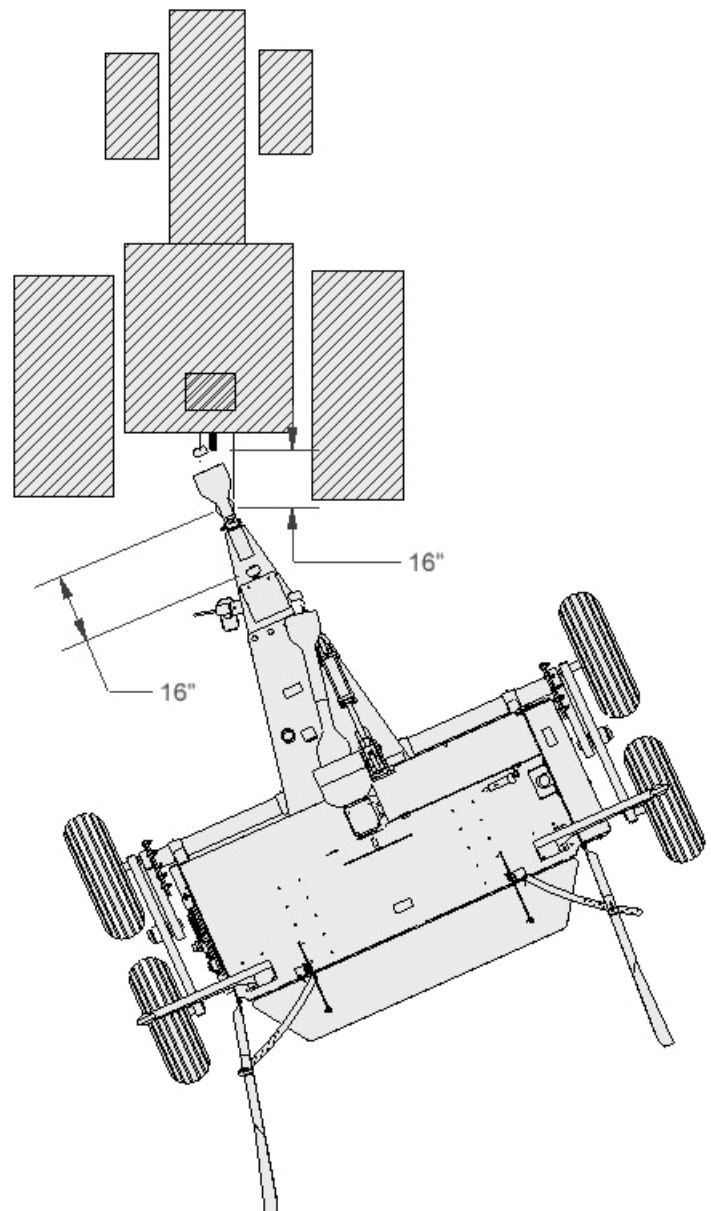

Transport Lock

Before transporting machine ensure the transport lock is in its LOCKED position. This provides a fail safe to hydraulic pressure keeping the Accelerator raised.

Refer to [Transport Safety, pg.2-3](#) for proper transportation of this machine.

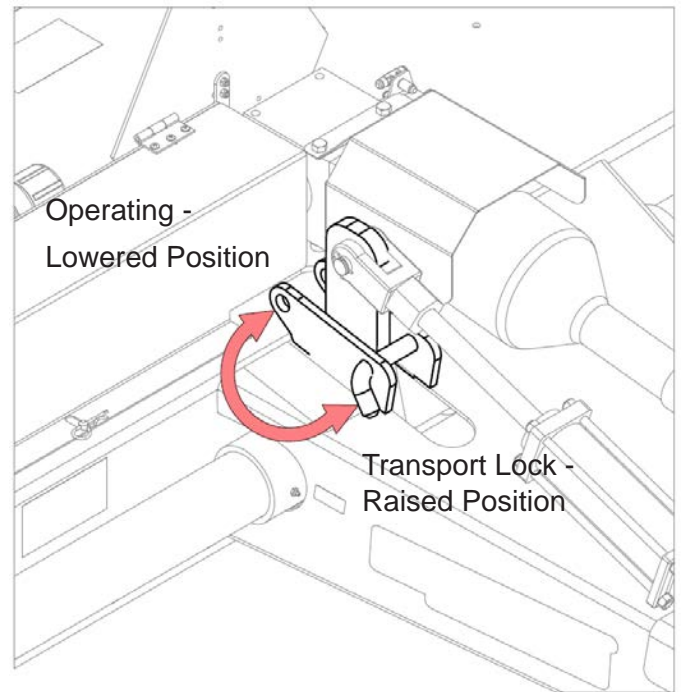

Section 4: Adjustments

Deflectors

The side **(A)** and horizontal **(B)** deflector(s) can be adjusted to accommodate many different windrow widths and heights. In general, the closer together the side deflectors are the narrower the windrow, and the higher the horizontal deflector, the taller the windrow.

To adjust:

1. Remove lock pins **(C)** from top of deflectors.
2. Pivot deflectors to new desired position.
3. Align deflector holes with nearest deflector arm holes **(D)**.
4. Reattach lock pins.

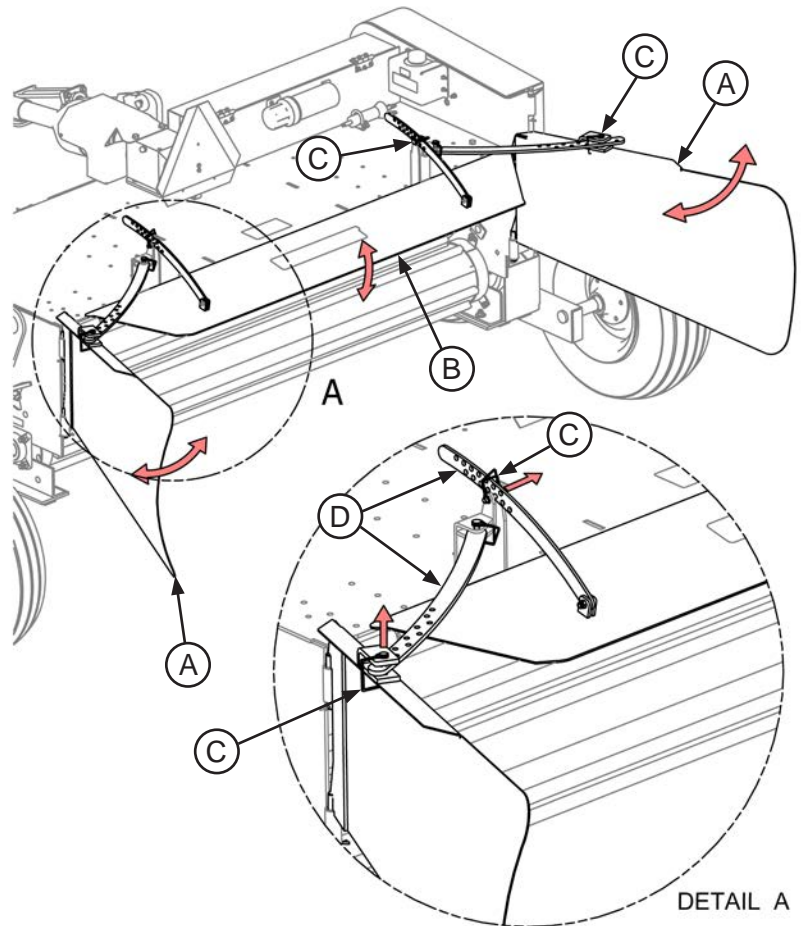

Roller Tensioning - Up to SN 22HCT101

The Tubeline Accelerator has spring tension settings on both the left and right side of the machine to set the tensioning of the two rollers. Increase the distance between rollers if leaves are being crushed or removed from plant. Decrease rollers spacing if plant stems are not being cracked open to allow moisture to escape.

1. To adjust the rollers, open the right side shield, and either loosen the nut **(A)** or tighten it for more or less tension.
2. Repeat process for left side.

NOTE: It is a good practice to make sure that both sides, left and right side tension springs **(B)** are set at the same tension rate.

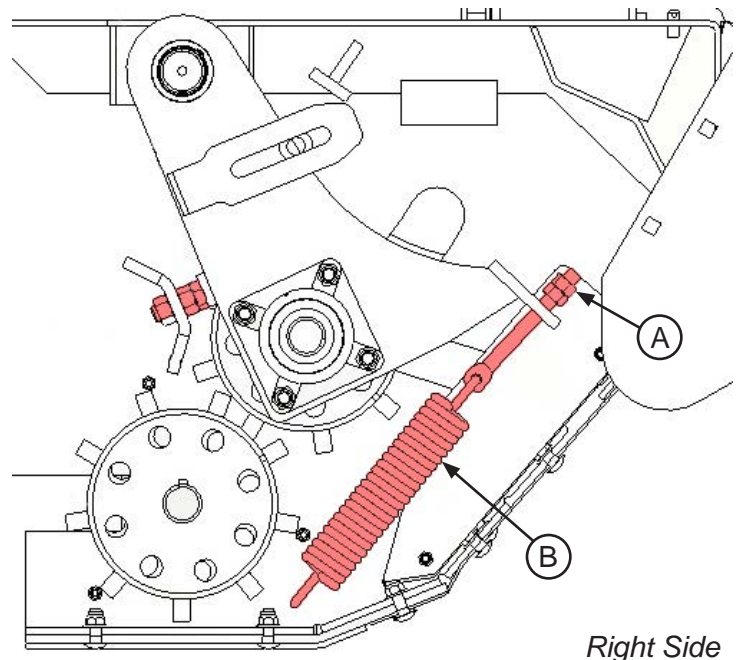

- To adjust roll spacing turn Stop Adjustment bolt in until rolls make light contact. Turn bolt out to provide slight clearance.
- Tighten lock nut.
- Adjust both sides.

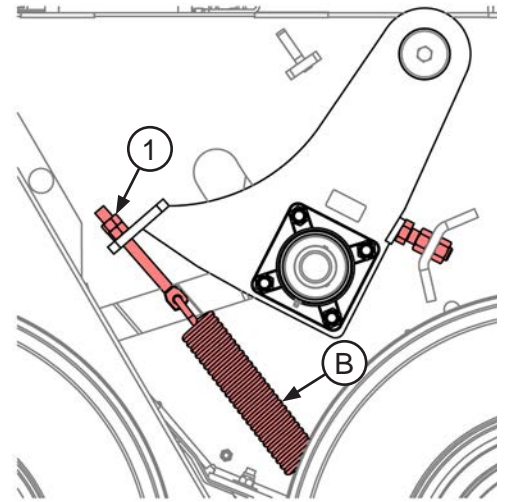

Roller Tensioning - SN 22HCT101 to Current

The updated version of the Accelerator requires the following steps to adjust the distance between the rollers.

1. Open right side shield.
2. Loosen 5/8" hex nuts **(A)** on slider **(B)**.
3. Turn Stop Adjustment bolt and nut **(C)** to move upper roller, increasing or decreasing the space between rollers **(D)** as desired.
4. Retighten slider nuts to lock into position.
5. The roller chain may be too tight or loose after roller tensioning. See [Roller Chain Tensioning, pg.4-3](#).

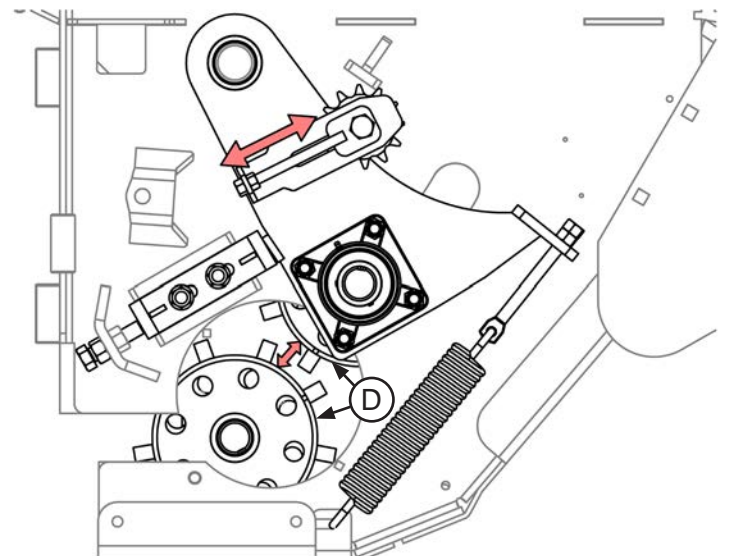
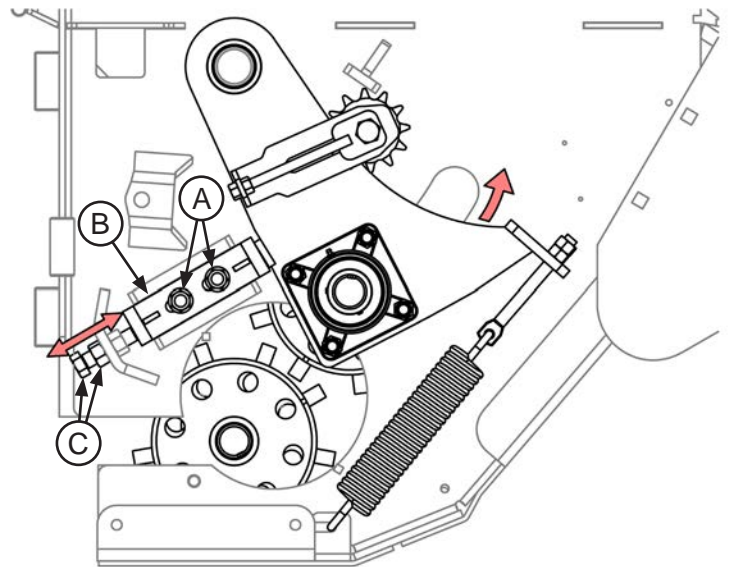

Roller Chain Tensioning

Over time roller chains can stretch and cause slipping or even come off of sprockets. To tighten the roller chain **(A)**:

6. Loosen the rear hex nut **(B)**.
7. Adjust front hex nut **(C)** to tighten chain.
8. Retighten rear hex nut to lock new position.

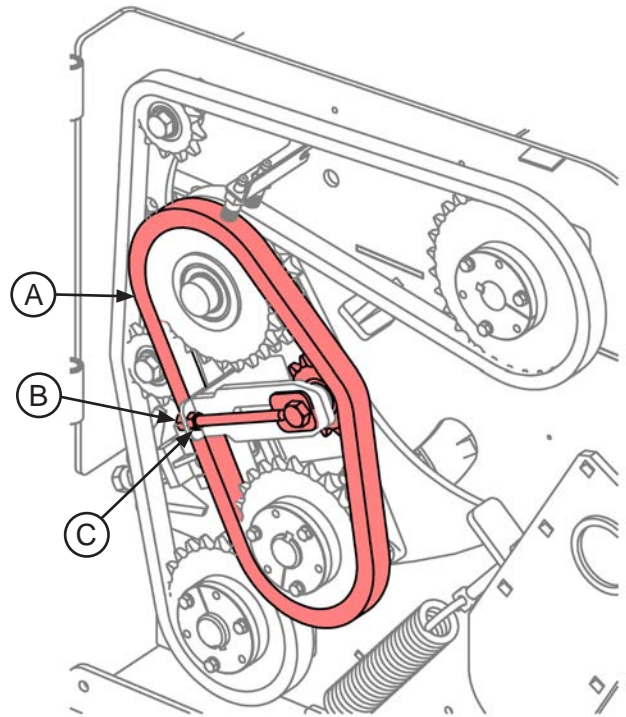

Section 5: Operation



WARNING

Refer to Safety Section before operating this machine.

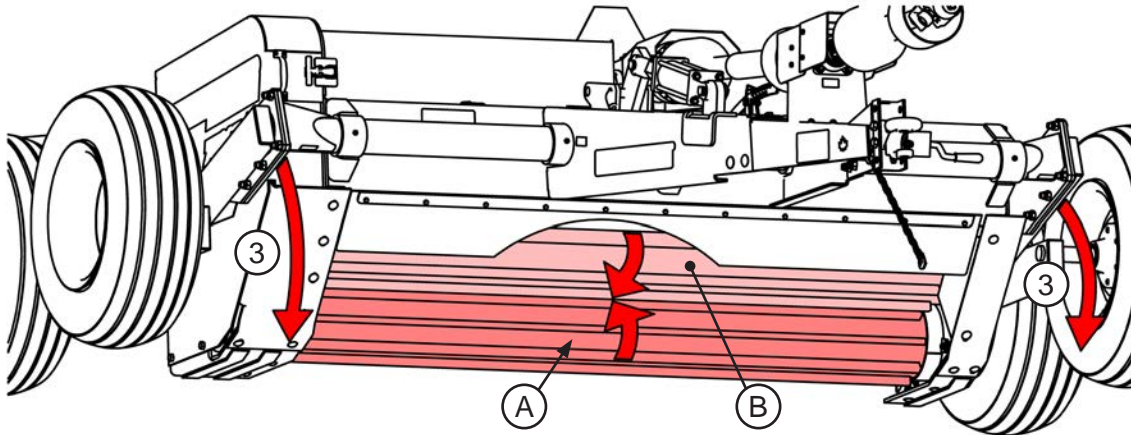

1. Attach the Accelerator to your power unit and move transport lock to rear storage holes to avoid cylinder damage while lowering Accelerator. Refer to [Section 3: Transportation](#).
2. Keep machine raised until Accelerator reaches start of desired row.
3. Apply hydraulic pressure and lower the Accelerator to desired height above foilage.
4. Engage PTO to start turning rollers. Bottom roller (**A**), top roller (**B**).

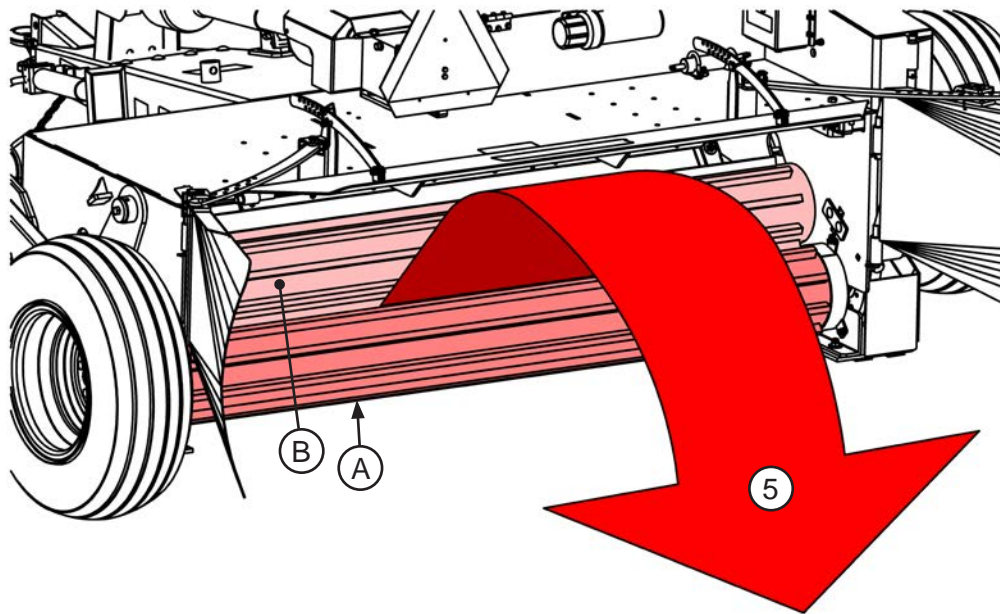

5. Drive down the row at a controlled speed, keeping the Accelerator in the middle of the row. The material should arch smoothly from the rollers, back onto the the field in windrows.
6. At end of row, raise Accelerator above foilage row while turning to next row.
7. Lower Accelerator at beginning of next row and repeat step 5 until operation complete.



WARNING

Engage the parking brake on the tractor, shut down the engine, and wait for all moving parts to stop before leaving the cab. Failure to comply could result in death or serious injury.

8. Once field has been completed, raise Accelerator, reset tranport lock pin to holes in front of cylinder lug.

Section 5: Lubrication

This section gives full details of the procedures necessary to maintain the Tubeline Accelerator at peak efficiency. Complete all checks and services in this section at the hour interval shown.

Note: Failure to complete the required maintenance at the interval shown can cause unnecessary downtime.

The recommended lubrication intervals are for average conditions. Perform lubrication more often when operating under adverse conditions.



Before lubricating the Tube-Line Accelerator always observe the following precautions:

Turn off tractor, set parking brake, remove key and wait for all moving parts to stop before leaving cab. Failure to comply could result in death or serious injury.

Grease Points Grease Point - PTO Knuckles

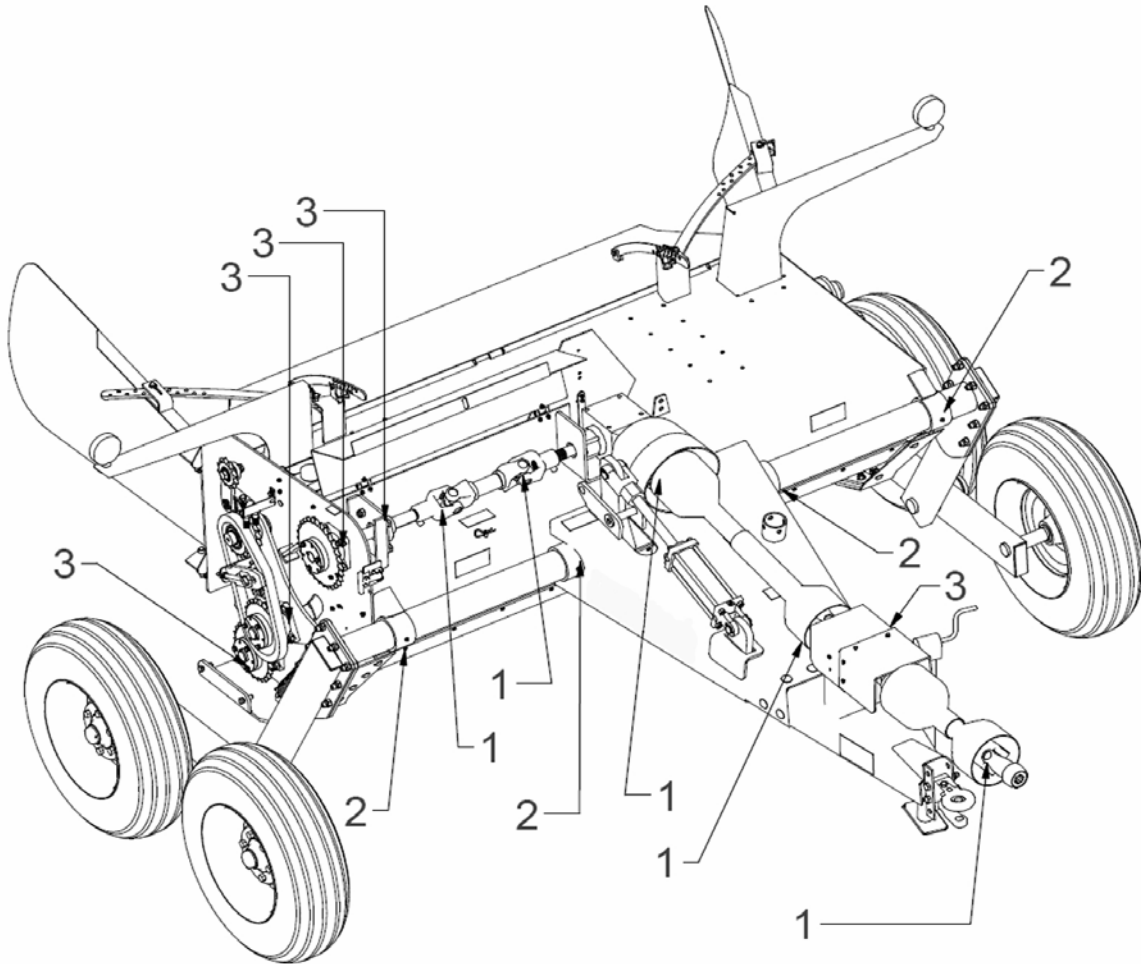

NUMBER	ITEM	INTERVAL
1	PTO Knuckles	Every 50 – 250 Hours
2	Lifting Pivot	Every 100 Hours
3	Pillow Block Bearing	Every 100 Hours

Apply 2 strokes of grease every 50 to 250 hours to point (1) (6 locations).

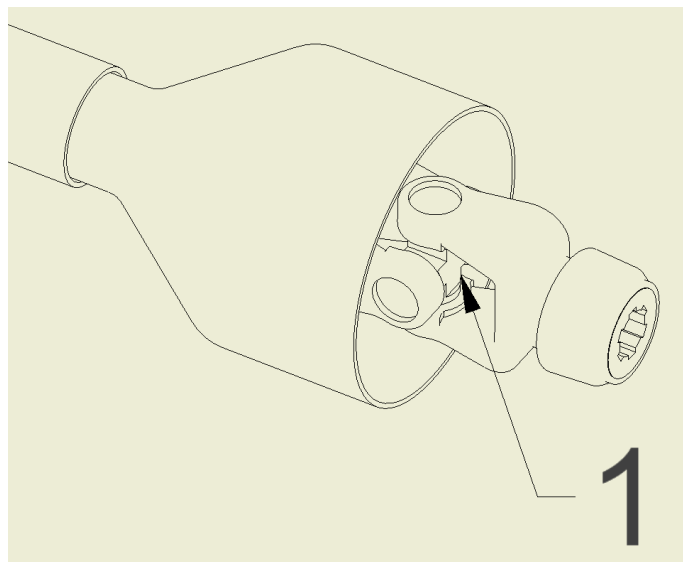

Grease Point - Lifting Pivot

Apply 5 strokes of grease every 100 hours at points (2); 5 locations.

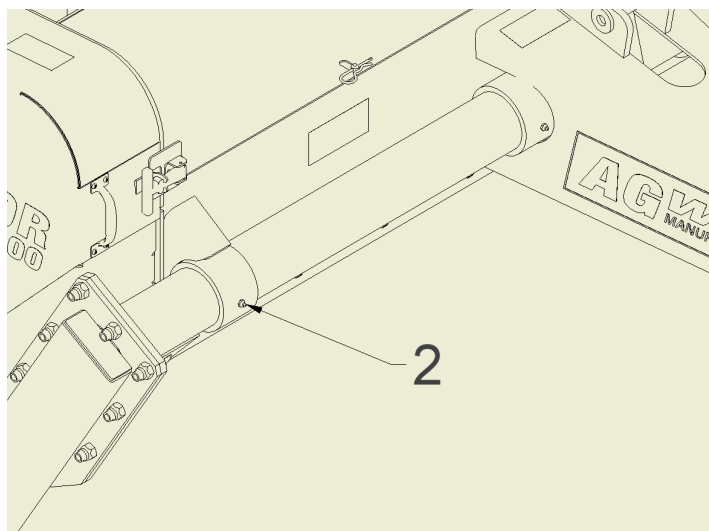

Grease Point - Pillow Block Bearing

Apply 2 strokes of grease every 100 hours at points (3); 6 locations.

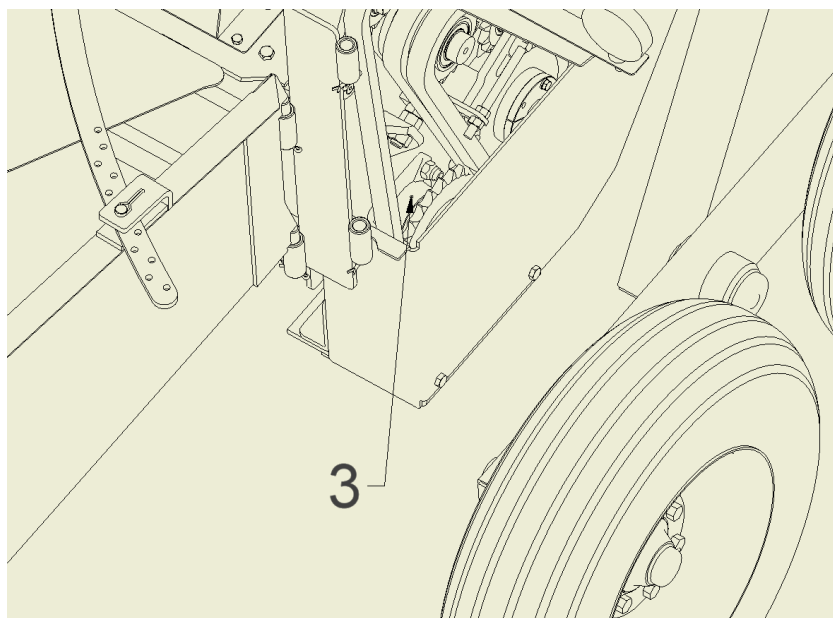

Section 6: Maintenance

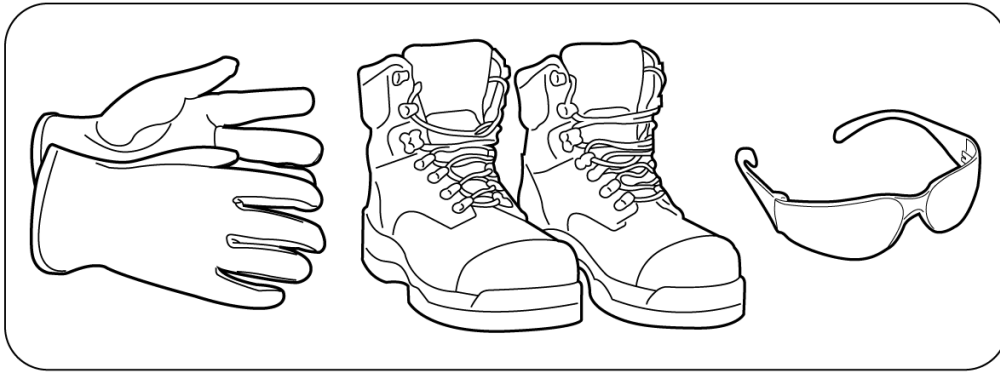

Complete all checks and services in this section at the hour interval shown.

NOTE: Failure to complete the required maintenance at intervals shown can cause unnecessary downtime.

The recommended intervals are for average conditions. Perform maintenance more often when operating the Tube-Line Accelerator under adverse conditions.

General checking of bolts, security pins and split pins must be carried out initially after the first 8 hours of use. Subsequently, check every 50 hours and whenever the machine is laid up for extended periods.



WARNING

Before performing any adjustments or maintenance on the Tube-Line Accelerator, observe these safety precautions:

Turn off tractor, set parking brake, remove key and wait for all moving parts to stop before leaving cab.

Failure to comply could result in death or serious injury.

DO NOT weld on or near rotating parts. Welding close to rotating parts will cause warping and will challenge the structural integrity.

DO NOT weld on or near rotating parts. Welding close to rotating parts may cause warping thus creating high stress loads for moving or rotating parts.

DO NOT weld on wheels. Welding on wheels may cause high stress and wheel failure.

DO NOT weld on wheels with a mounted tire, Welding on wheels with a mounted tire may cause tire to burst, causing serious injury or death.

Friction Clutch Maintenance

If the clutch has not been operated for 1 season we recommend the following.

1. Make sure the tractor is off and the PTO is disengaged.
2. Disconnect the driveline from the tractor.
3. Locate the long bolts on the outside of the clutch pack. Loosen the bolts until all are finger tight, then tighten each, one half turn.
4. Attach the implement to the tractor at the hitch pin, and the driveline to the tractor PTO.

5. Turn the tractor on. Engage the PTO clutch and run for a few seconds, or until the clutch visibly smokes.
6. Disengage the tractor PTO clutch off the tractor. Keep clear of the machine until all parts stop moving.
7. Disconnect the driveline from the tractor.
8. Tighten the long bolts on the outside of the clutch pack until the compression plate is in full contact with the housing.
9. If the clutch contains an integral overrunning clutch, make sure the clutch spins freely in one direction.

Daily Maintenance

Careful inspection and service of the Tubeline Accelerator prior to operation each day will prevent needless breakdowns and delays in the field. Make the following checks and adjustments.

1. Be alert for loose hardware and tighten or replace as required.
2. Lubricate the Tube-Line Accelerator according to the instruction in the “Lubrication” section of this manual.

Preseason Service

Prior to beginning the harvest, after off season storage, take the following steps to be certain the Tubeline Accelerator is in good condition.

1. Inspect and make adjustment to the friction clutch as necessary. (refer to page 5-2).
2. Lubricate the Tube-Line Accelerator according to the “Lubrication” section of the manual.
3. Tighten or replace any damaged or missing fasteners.

End of Season Service

Prior to storing the Tube-Line Accelerator during the off season, follow these steps to ensure easier preparation for the next season and longer Tubeline Accelerator life.

1. Pack all grease points with grease, see [Section 5: Lubrication](#) for grease points location.
2. Remove all crop material from the Tubeline Accelerator.

Section 7: Troubleshooting

Problem: Material wraps on the bottom roller.

Cause 1: Accelerator is set too low and is contacting the ground.

Cause 2: Slip clutch is not set tight enough, causing the slip clutch to slip.

Remedy 1: Adjust the rod on the cylinder so that the bottom roller is 1-2" off the ground.

Remedy 2: Tighten tension adjustments on slip clutch 2 rounds each and test, repeat if necessary.

Problem: Main PTO drive knuckles chatter when turning a sharp corner.

Cause: The distance from draw pin to end of the stub shaft on Accelerator and the distance from draw pin to end of PTO in tractor is not equal. (see pg 2-2)

Remedy: Adjust drawbar on tractor so that the distance from draw pin to end of stub shafts are equal each being approximately 16". (see page 2-2)

Problem: After product has passed through the Accelerator the product is not crushed or broken.

Cause 1: The rollers on the Accelerator are too far apart allowing the product to pass through without properly conditioning it.

Cause 2: The spring tension on rollers is not set tight enough.

Remedy 1: Adjust roller spacing.

Remedy 2: Adjust spring tension.

Problem: Rollers chatter

Cause 1: Rollers too close together.

Cause 2: Roller timing is incorrect.

Remedy 1: Adjust the stop for the rollers (see page 3-1)

Remedy 2: Remove a link from the chain or readjust hubs on sprockets to correct the timing.

Section 8: Parts Breakdowns & Lists

Illustrations may differ slightly from actual machine.

Main Frame Components

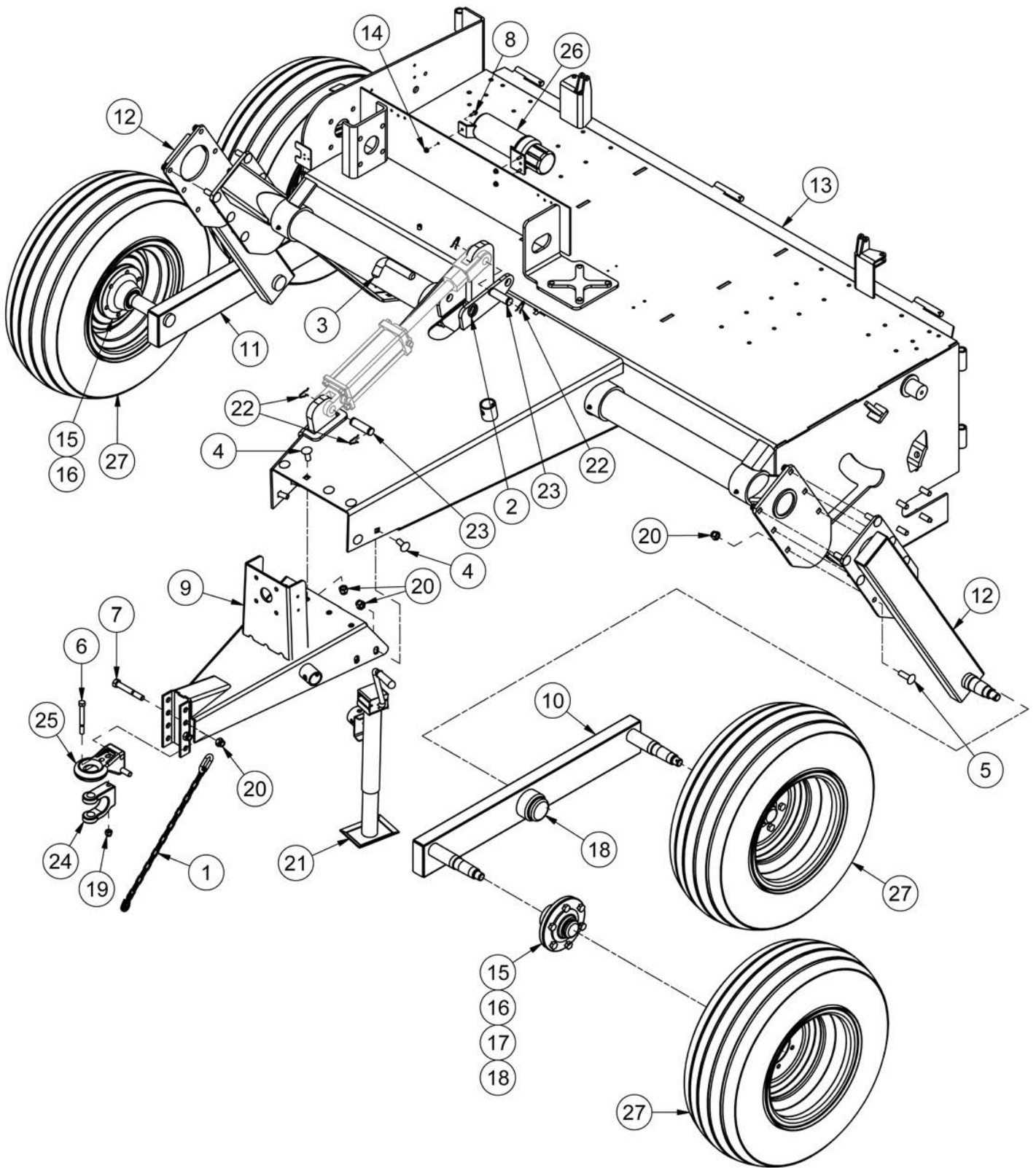

Main Frame Components

ITEM	QTY	PART NUMBER	DESCRIPTION	NOTE
1	1	25261	Safety Chain 10000 # 59"	
2	1	25680	Linch Pin 3/16 X 1.5	
3	1	43404	Transport Lock Pin	
4	8	CB5/8-11X1.5CZ5	Carriage Bolt - 5/8-11 x 1 1/2" Grade 5 Zinc	
5	12	CB5/8-11X2CZ5	Carriage Bolt - 5/8-11 x 2" Grade 5 Zinc	
6	1	HB1/2-13X4.5Z5	Hex Bolt 1/2-13x4 1/2 Gr5 Zinc Plated Hex Cap Screw	
7	2	HB5/8-11X4.5Z5	Hex Bolt 5/8-11x4 1/2 Gr5 Zinc Plated Hex Cap Screw	
8	3	HBC1/4X0.75	Hex Bolt Cerrated 1/4-20 x 3/4 Zinc Flange Bolt	
9	1	HC-01b	Tongue	
10	1	HC-02	Left Tandem Axle	
11	1	HC-02M	Right Tandem Axle	
12	2	HC-03	Lift Arm	
13	1	HC-7501c	Frame	
14	3	HNC1/4	Serrated Hex Nut	
15	4	HUB 4000#	Complete Assembly HUB4000	Tandem Axle
16	4	HUB 4000-CCS	HUB 4000 Complete Bearings and Seal Kit	Tandem Axle
17	2	HUB 5000	Complete Assembly HUB5000	Single Axle
18	2	HUB 5000-CCS	HUB 5000 Complete Bearings and Seal Kit	
19	1	LN1/2-13NCZ5	LN 1/2-13 Zinc Plated Nylon Insert Lock Nut	
20	22	LN5/8-11NCZ5	LN 5/8-11 Zinc Plated Nylon Insert Lock Nut	
21	1	PP00302	15" Implement Jack	
22	4	PP00346	3/4 id, Hair Pin Cotter	
23	2	PP00347	Cylinder Pin	
24	1	PP00893	Clevis, PPI-107VR	
25	1	PP00894	Implement Hitch, PPI-126VR	
26	1	TL5X2-201-111	Operator's Manual Holder	
27	4	WHE 11LX15X8	11L X 15 8 Ply Tubeless Tire	

Rollers

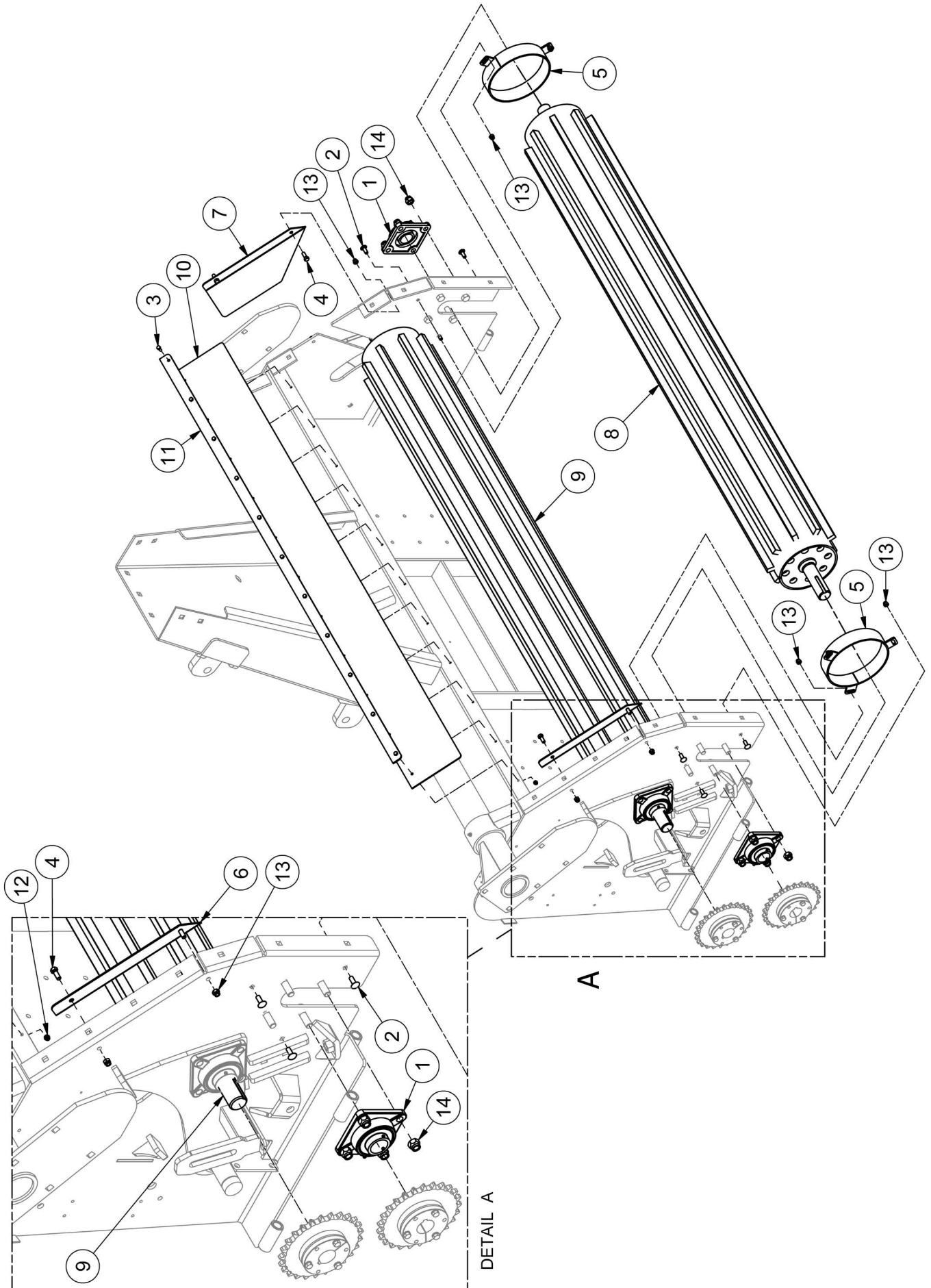

Rollers

ITEM	QTY	PART NUMBER	DESCRIPTION	NOTE
1	2	BEA UCF209-28R3	FS209-28 - 1.75 - 4 Bolt with Locking Collar	
2	6	CB3/8-16X1CZ5	Carriage Bolt - 3/8-16 x 1" Grade 5 Zinc	
3	11	HB1/4-20X0.75Z5	Hex Bolt 1/4-20x3/4 Gr5 Zinc Plated Hex Cap Screw	
4	4	HB3/8-16X1Z5	Hex Bolt 3/8-16x1 Gr5 Zinc Plated Hex Cap Screw	
5	2	HC-04	Hay Guard	
6	1	HC-106	Right Roller Guard	
7	1	HC-106M	Left Roller Guard	
8	1	HC-7502	Bottom Roller	
9	1	HC-7503	Top Roller	
10	1	HC-7508	Stone Guard for Accelerator	9500T Model: HC-9508
11	1	HC-7509	Guard Bolt Plate	9500T Model: HC-9509
12	11	LN1/4-20NCZ5	LN 1/4-20 Zinc Plated Nylon Insert Lock Nut	
13	10	LN3/8-16NCZ5	LN 3/8-16 Zinc Plated Nylon Insert Lock Nut	
14	8	LN5/8-11NCZ5	LN 5/8-11 Zinc Plated Nylon Insert Lock Nut	

Driveline

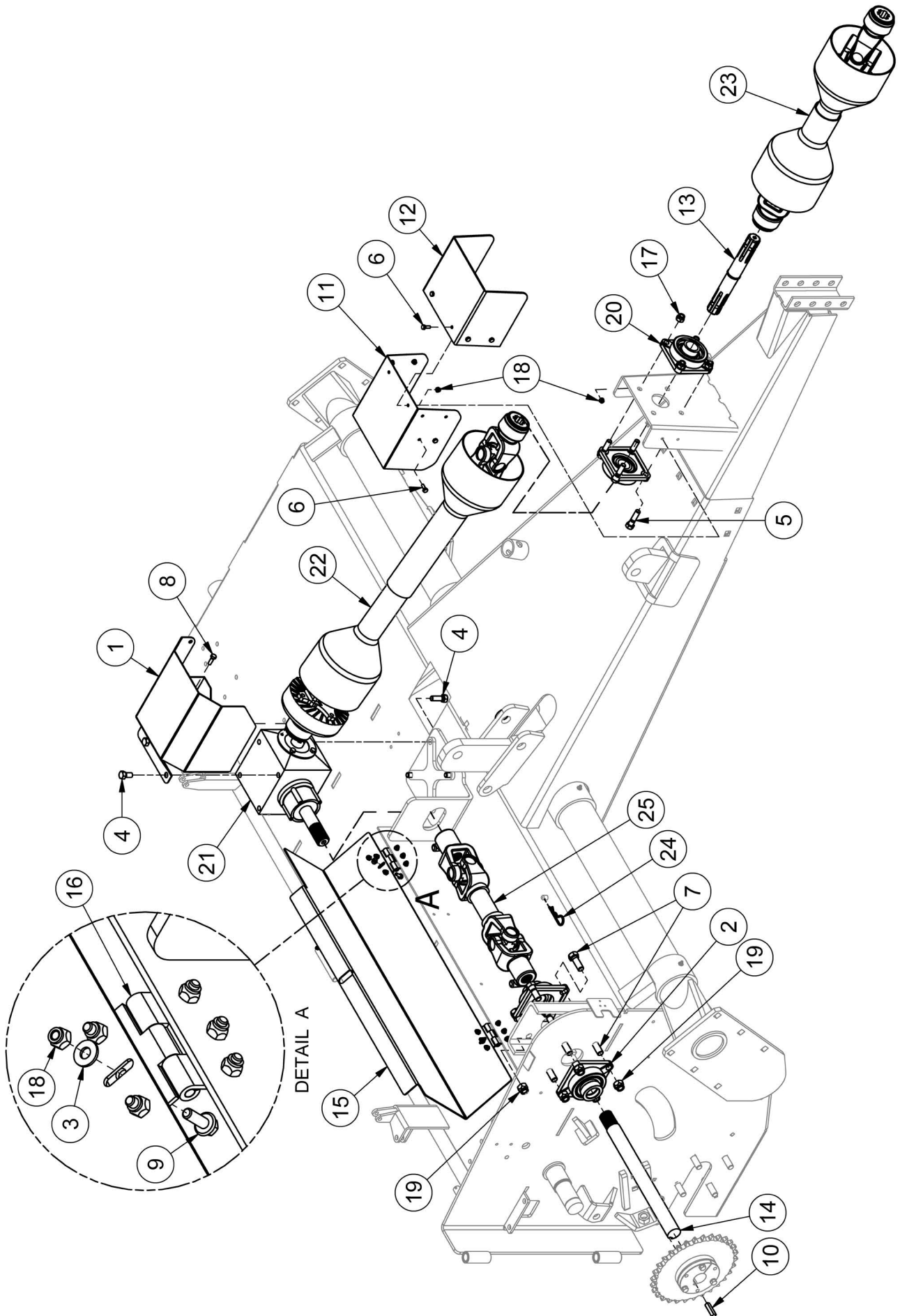

Driveline

ITEM	QTY	PART NUMBER	DESCRIPTION	NOTE
1	1	28596	Accelerator PTO Shield Cover	
2	1	BEA UCF208-24R3	Flange Bearing 4 Bolt -Triple Seal- Ductile Iron	
3	2	FW 1/4	Flatwasher - 1/4" Zinc Plated USS	
4	4	HB1/2-13X1.5Z5	Hex Bolt 1/2-13x1 1/2 Grade 5 Zinc Plated Hex Cap Screw	
4	2	HB1/2-13X1Z5	Hex Bolt 1/2-13x1 Grade 5 Zinc Plated Hex Cap Screw	
5	4	HB1/2-13X2Z5	Hex Bolt 1/2-13x2 Grade 5 Zinc Plated Hex Cap Screw	
6	10	HB1/4-20X0.75Z5	Hex Bolt 1/4-20x3/4 Grade 5 Zinc Plated Hex Cap Screw	
7	8	HB5/8-11X1.75Z5	Hex Bolt 5/8-11x1 3/4 Grade 5 Zinc Plated Hex Cap Screw	
8	4	HB5/16-18X1Z5	Hex Bolt 5/16-18x1 Grade 5 Zinc Plated Hex Cap Screw	
9	12	HBC1/4X0.75	Hex Bolt Cerrated 1/4-20 x 3/4 Zinc Flange Bolt	
10	1	HC-063	Key	
11	1	HC-072	Shield	
12	1	HC-094	Rubber Shield	
13	1	HC-117	540 Stub Shaft	
14	1	HC-142	Drive Shaft 1.5 " x 17.88	
15	1	HC-144c	Small Shield	
16	2	HIN 3.0 X 3.0	Hinge - 3.0" X 3.0" Zinc Non-Removable Pin Hinge	
17	4	LN1/2-13NCZ5	LN 1/2-13 Zinc Plated Nylon Insert Lock Nut	
18	22	LN1/4-20NCZ5	LN 1/4-20 Zinc Plated Nylon Insert Lock Nut	
19	8	LN5/8-11NCZ5	LN 5/8-11 Zinc Plated Nylon Insert Lock Nut	
20	2	PP00309	UCF207-22 1.375 4 Bolt Flange Bearing	
21	1	PP00337	T-27 Comer Gear Box	
22	1	PP00338	Drive Shaft with Slip Clutch	See Pg.9-1
23	1	PP00339	PTO Drive Shaft	See Pg.9-2
24	1	PP00405	Hitch Pin Clip	
25	1	PP00836/PP00837	Cross Drive Shaft	See Pg.9-3/4

Discharge Shields

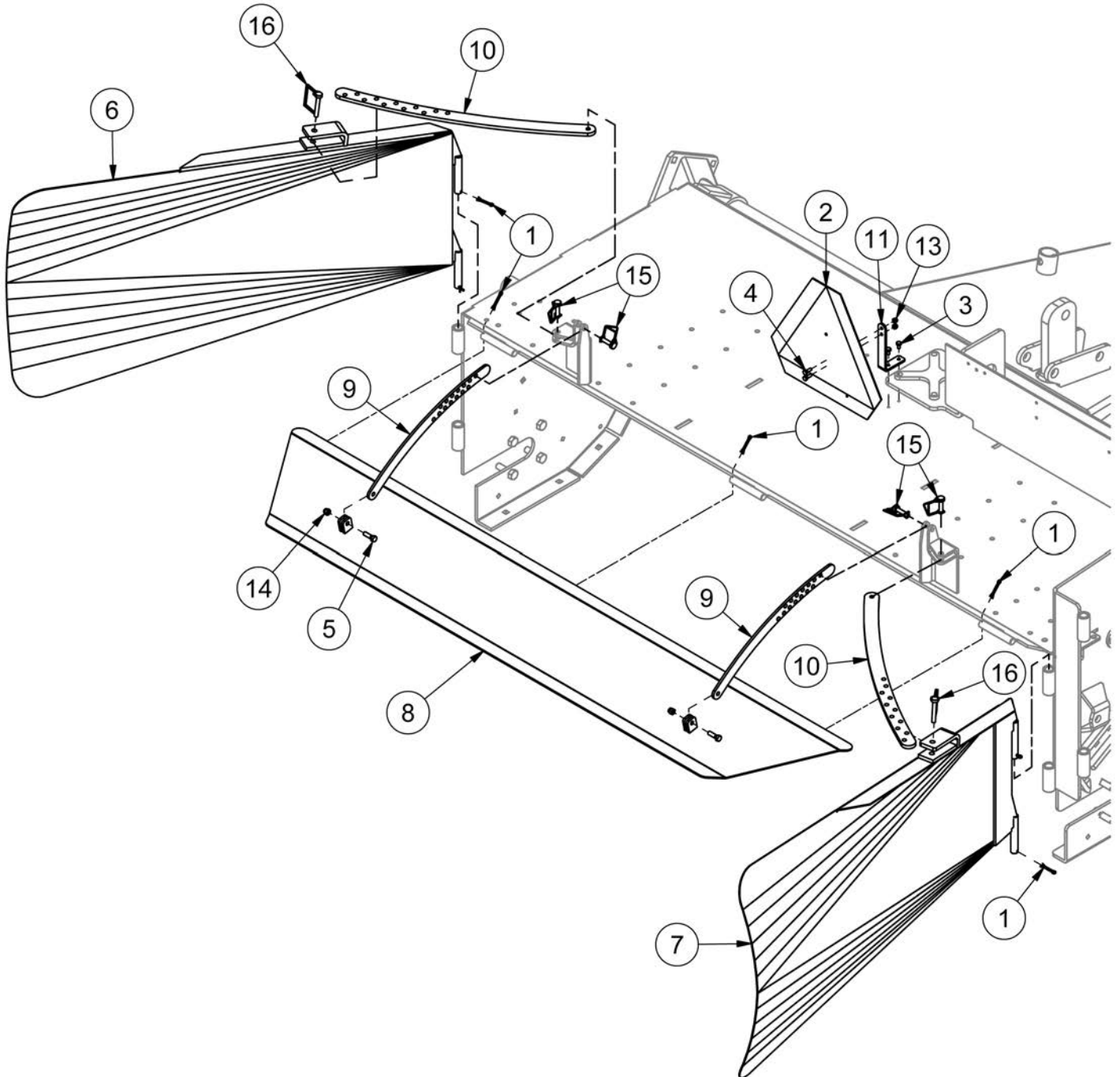

Discharge Shields

ITEM	QTY	PART NUMBER	DESCRIPTION
1	7	CP 3/16 X 1 1/2	Pin,Cotter - 3/16" X 1 1/2" Zinc Finish Extended Prong
2	1	DESMV	Slow Moving Vehicle Sign
3	2	HB1/4-20X0.5Z5	Hex Bolt 1/4-20x1/2 Grade 5 Zinc Plated Hex Cap Screw
4	2	HB1/4-20X0.75Z5	Hex Bolt 1/4-20x3/4 Grade 5 Zinc Plated Hex Cap Screw
5	2	HB3/8-16X1.25Z5	Hex Bolt 3/8-16x1 1/4 Grade 5 Zinc Plated Hex Cap Screw
6	1	HC-06b	Left Side Deflector Assembly
7	1	HC-06bM	RightSide Deflector Assembly
8	1	HC-75A04	Deflector
9	2	HC-105	Deflector Arm
10	2	HC-109	Side Deflector Arm
11	1	HC-157	Yield Bracket
13	2	LN1/4-20NCZ5	LN 1/4-20 Zinc Plated Nylon Insert Lock Nut
14	2	LN3/8-16NCZ5	LN 3/8-16 Zinc Plated Nylon Insert Lock Nut
15	4	LP B1996	Pin - Lock Pin 3/8 X 1 3/8
16	2	LPS 3/8X2.1/2	Pin - 3/8" x 2-1/2" Zinc Square Single Wire Snapper Pin

Left Side Panel

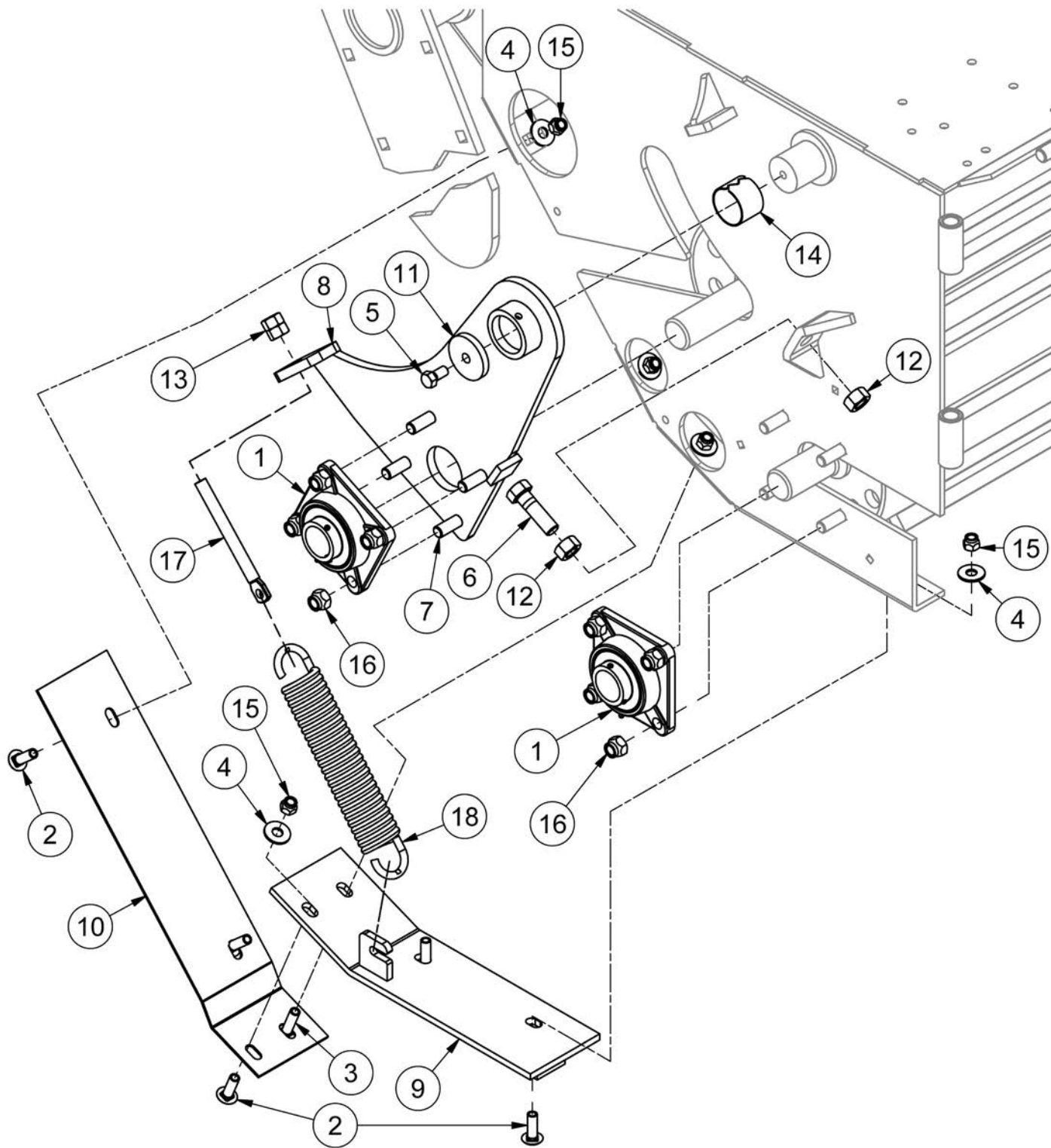

Left Side Panel

ITEM	QTY	PART NUMBER	DESCRIPTION
1	2	BEA UCF209-28R3	Flange Bearing, Triple Seal, Ductile Iron
2	5	CB1/2-13X1.5CZ5	Carriage Bolt - 1/2-13 x 1 1/2" Grade 5 Zinc
3	1	CB1/2-13X1.75CZ5	Carriage Bolt - 1/2-13 x 1 3/4" Grade 5 Zinc
4	6	FW 1/2	Flatwasher - 1/2" Zinc Plated USS
5	1	HB1/2-13X1Z5	Hex Bolt 1/2-13x1 Grade 5 Zinc Plated Hex Cap Screw
6	1	HB3/4-10X2.5Z5	Hex Bolt 3/4-10x2 1/2 Grade 5 Zinc Plated Hex Cap Screw
7	4	HB5/8-11X2Z5	Hex Bolt 5/8-11x2 Grade 5 Zinc Plated Hex Cap Screw
8	1	HC-12c	Left Pivot Arm
9	1	HC-13	Left Skid Shoe
10	1	HC-067b	Left Hay Guard
11	1	HC-075	Pivot Washer
12	2	HN3/4-10CZ5	Hex Nut 3/4"-10 Grade 5 Zinc Plated Finished
13	2	HN5/8-11CZ5	Hex Nut 5/8"-11 Grade 5 Zinc Plated Finished
14	1	INS22601150	2.262 OD x 2.012 ID (2.125OD x 2 ID) Insert Bushing
15	6	LN1/2-13NCZ5	LN 1/2-13 Zinc Plated Nylon Insert Lock Nut
16	8	LN5/8-11NCZ5	LN 5/8-11 Zinc Plated Nylon Insert Lock Nut
17	1	PP00051	Flat Eyebolt - 5/8 X 7
18	1	PP00054	Snowplow Spring (LA-11-1515)

Right Side Shields

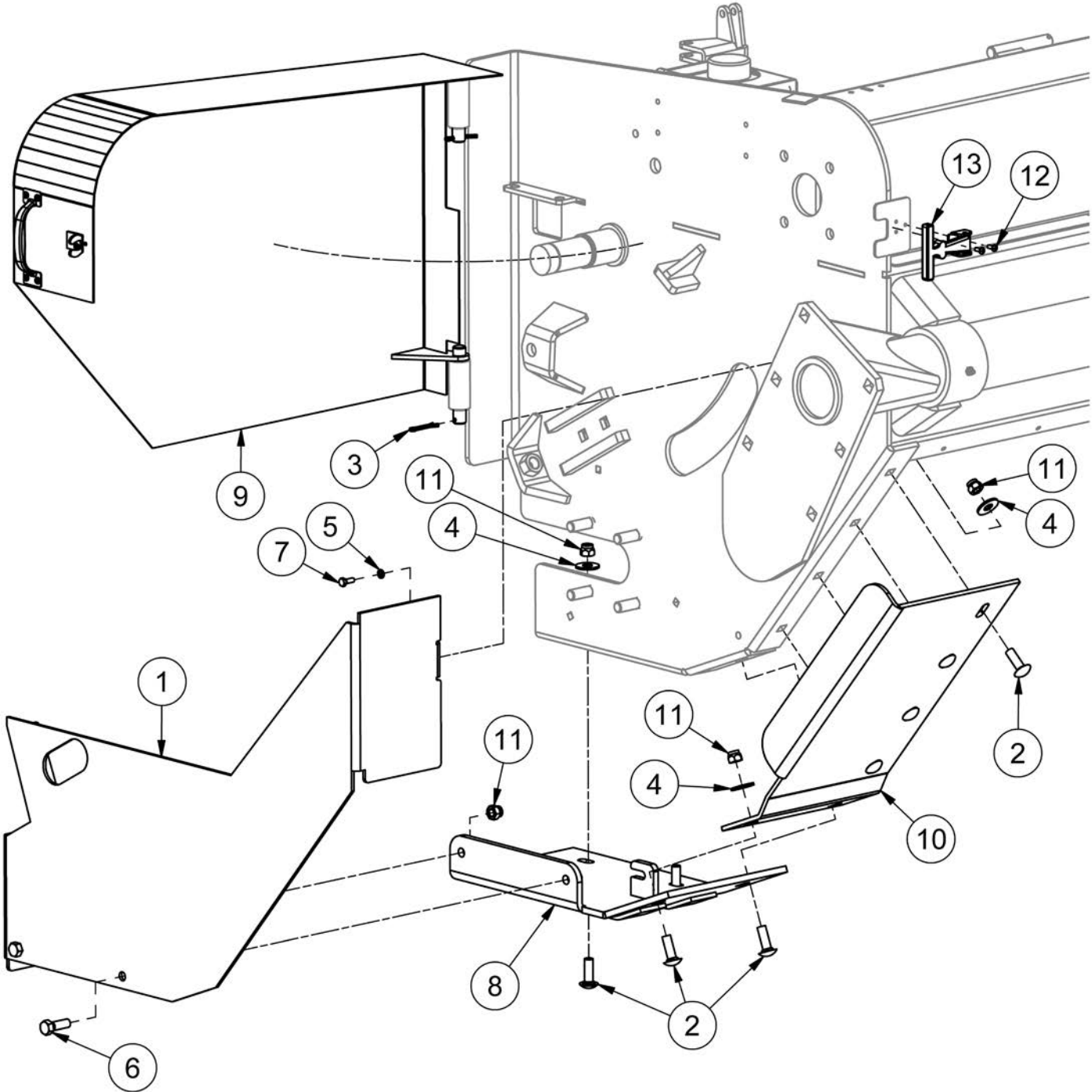

Right Side Shields

ITEM	QTY	PART NUMBER	DESCRIPTION	NOTE
1	1	47479	Bottom Shield ASM	HC-147c prior to SN 22HCT101
2	8	CB1/2-13X1.5CZ5	Carriage Bolt - 1/2-13 x 1 1/2" Grade 5 Zinc	
3	2	CP 3/16 X 1 1/2	Pin,Cotter - 3/16" X 1 1/2" Zinc Finish Extended Prong	
4	8	FW 1/2	Flatwasher - 1/2" Zinc Plated USS	
5	1	FW 1/4	Flatwasher - 1/4" Zinc Plated USS	
6	2	HB1/2-13X1.5Z5	Hex Bolt 1/2-13x1 1/2 Gr5 Zinc Plated Hex Cap Screw	
7	1	HB1/4-20X0.75Z5	Hex Bolt 1/4-20x3/4 Gr5 Zinc Plated Hex Cap Screw	
8	1	HC-05b	Right Skid Shoe	
9	1	HC-17c	Shield Assembly	
10	1	HC-040b	Right Hay Guard	
11	10	LN1/2-13NCZ5	LN 1/2-13 Zinc Plated Nylon Insert Lock Nut	
12	2	MS #10X24X0.5	Machine Screw - (Inch)	
13	1	TL500-100-041	Rubber Latch	

Right Side Chain

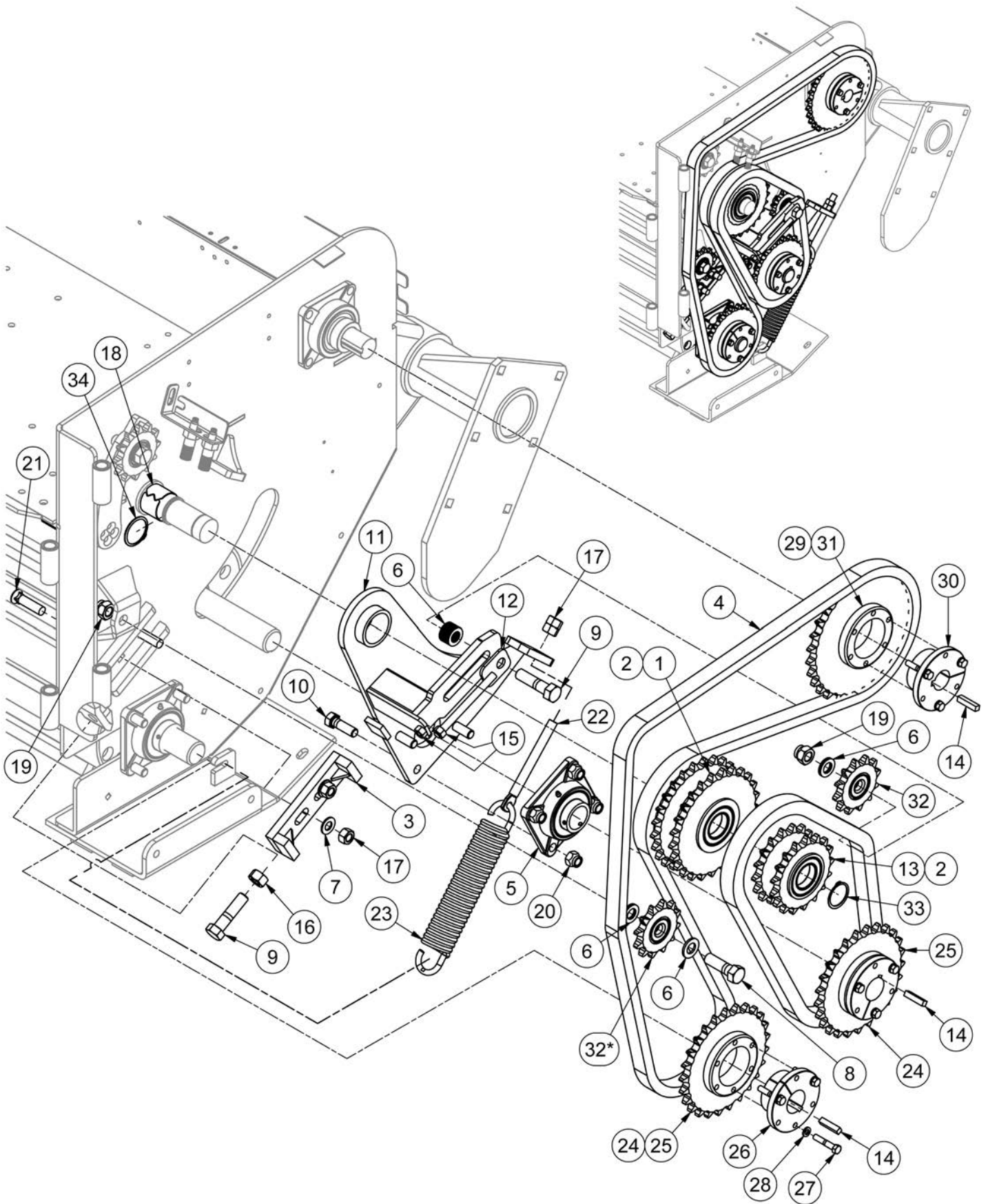

* Lower Inside Chain Idler Sprocket used starting with SN 12HCT01.

Right Side Chain

ITEM	QTY	PART NUMBER	DESCRIPTION	NOTE
1	1	30275	25 Tooth Double 80 Sprocket	SN 12HCT01 - Current
2	2	PP00900	Ball Bearing #6009 45X75X16mm	
3	1	49476	Accelerator Slider ASM	SN 22HCT101 - Current
4	1	AC-CHAIN-01	80 Series Chain/ 59 Links	
5	1	BEA UCF209-28R3	Flange Bearing, Triple Seal, Ductile Iron	
6	16	FW 3/4	Flatwasher - 3/4" Zinc Plated USS	
7	2	FW 5/8	Flatwasher - 5/8" Zinc Plated USS	
8	2	HB3/4-10X2.5Z5	Hex Bolt 3/4-10x2 1/2 Gr5 Zinc Plated Hex Cap Screw	
9	2	HB3/4-10X3Z5	Hex Bolt 3/4-10x3 Gr5 Zinc Plated Hex Cap Screw	
10	4	HB5/8-11X2Z5	Hex Bolt 5/8-11x2 Gr5 Zinc Plated Hex Cap Screw	
11	1	HC-10c	Right Pivot Arm	
12	1	HC-14c	Threaded Rod	
13	1	HC-28	17 Tooth Double Sprocket	Up to SN 11HCT15
14	3	HC-063	Key	
15	2	HN1/2-13CZ5	Hex Nut 1/2"-13 Grade 5 Zinc Plated Finished	
16	1	HN3/4-10CZ5	Hex Nut 3/4"-10 Grade 5 Zinc Plated Finished	
17	4	HN5/8-11CZ5	Hex Nut 5/8"-11 Grade 5 Zinc Plated Finished	
18	1	INS226201150	Insert Bushing 2.262 OD x 2.012 ID x 1.50 Long	
19	2	LN3/4-10NCZ5	LN 3/4-10 Zinc Plated Nylon Insert Lock Nut	
20	4	LN5/8-11NCZ5	LN 5/8-11 Zinc Plated Nylon Insert Lock Nut	
21	2	PB 5/8-11X2.5	Plow Bolts - 5/8-11 x 2 1/2 Flat Head Gr.5	SN 22HCT101 - Current
22	1	PP00051	Flat Eyebolt - 5/8 X 7	
23	1	PP00054	Snowplow Spring (LA-11-1515)	
24	2	PP00303	SPR80F25 Taper Lock Sprocket Assembly 1.75" Bore	Items 25-28
25	1	PP00304	SPR80F25 Taper Lock Sprocket	
26	1	PP00305	Taper Lock Bushing 1 3/4 Shaft	
27	3	HB 3/8-16X2 Z5	Hex Bolt 3/8-16x2 Gr5 Zinc Plated Hex Cap Screw	
28	3	LW 3/8	LW - 3/8" Zinc Plated Medium Split	
29	1	PP00318	SPR80F30 Taper Lock Sprocket Assembly 1.5" Bore	Items 27,28,30,31
30	1	PP00319	Taper Lock Bushing 1.5	
31	1	PP00320	SPR80F30 Taper Lock Sprocket	
32	2	PP00342	Sprocket - 80SF11 X .75 Bore Idler	
33	1	RR 1.75	Retaining Ring-1 3/4- External	
34	1	RR 2	Retaining Ring-2- External	

* Lower Inside Chain Idler Sprocket used starting with SN 12HCT01.

Rosta Tensioner - Chain Oiler

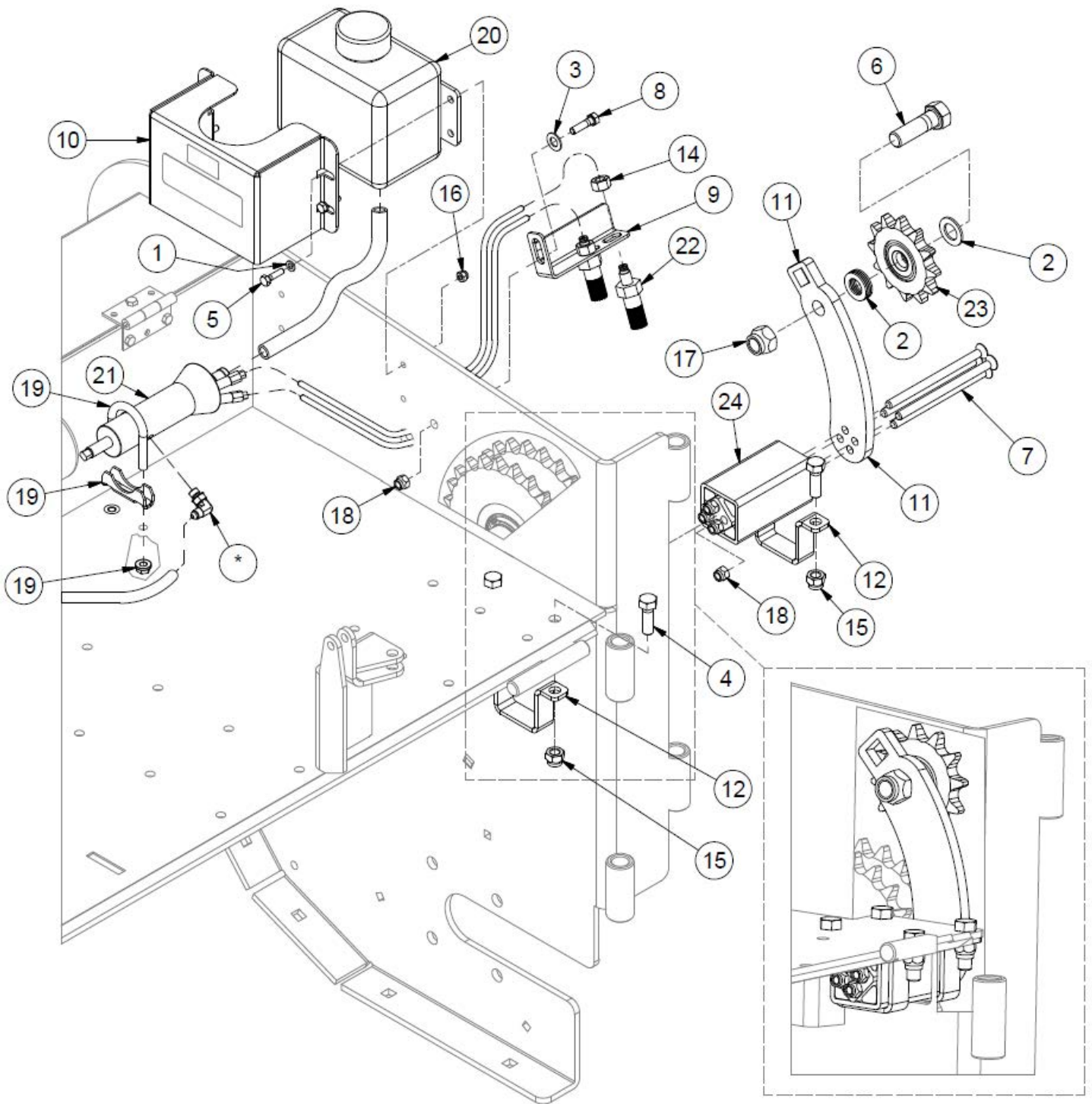

Rosta Tensioner - Chain Oiler

ITEM	QTY	PART NUMBER	DESCRIPTION
1	4	FW 1/4	Flatwasher - 1/4" Zinc Plated USS
2	5	FW 3/4	Flatwasher - 3/4" Zinc Plated USS
3	1	FW 7/16	Flatwasher - 7/16" Zinc Plated USS
4	4	HB 1/2-13X1.5 Z5	Hex Bolt 1/2-13x1 1/2 Grade 5 Zinc Plated Hex Cap Screw
5	4	HB 1/4-20X1 Z5	Hex Bolt 1/4-20x1 Grade 5 Zinc Plated Hex Cap Screw
6	1	HB 3/4-10X2.5 Z5	Hex Bolt 3/4-10x2 1/2 Grade 5 Zinc Plated Hex Cap Screw
7	4	HB 3/8-16X6 FHSCS	Hex Bolt - 3/8"-16 x 6" Flat Socket Cap Screw
8	1	HB 5/16-18X1.25 Z5	Hex Bolt 5/16-18x1 1/4 Grade 5 Zinc Plated Hex Cap Screw
9	1	HC-098b	HRP 10 GA
10	1	HC-132	HRP 12 GA
11	1	HC-166c	HRP .5
12	2	HC-167c	HRP .188
14	2	HN 1/2	Hex Nut 1/2"-13 Grade 5 Zinc Plated Finished
15	4	LN 1/2 N	LN 1/2-13 Zinc Plated Nylon Insert Lock Nut
16	4	LN 1/4 N	LN 1/4-20 Zinc Plated Nylon Insert Lock Nut
17	1	LN 3/4 N	LN 3/4-10 Zinc Plated Nylon Insert Lock Nut
18	1	LN 3/8 N	LN 3/8-16 Zinc Plated Nylon Insert Lock Nut
19	1	MC1 1/2	Muffler Clamp 1 1/2" Pipe (MC7112)
20	1	PP00072	Oil Reservoir- 2 Quart
21	1	PP00087	Lube Minder - 2 Port Pump
22	2	PP00088	Oiler Brush
23	1	PP00342	Sprocket -80SF11 x .75 Bore Idler
24	1	PP-00982	Rosta Tensioner
*		Pg.8-36	See Hydraulic Layout for hydraulic components

Hydraulic Layout

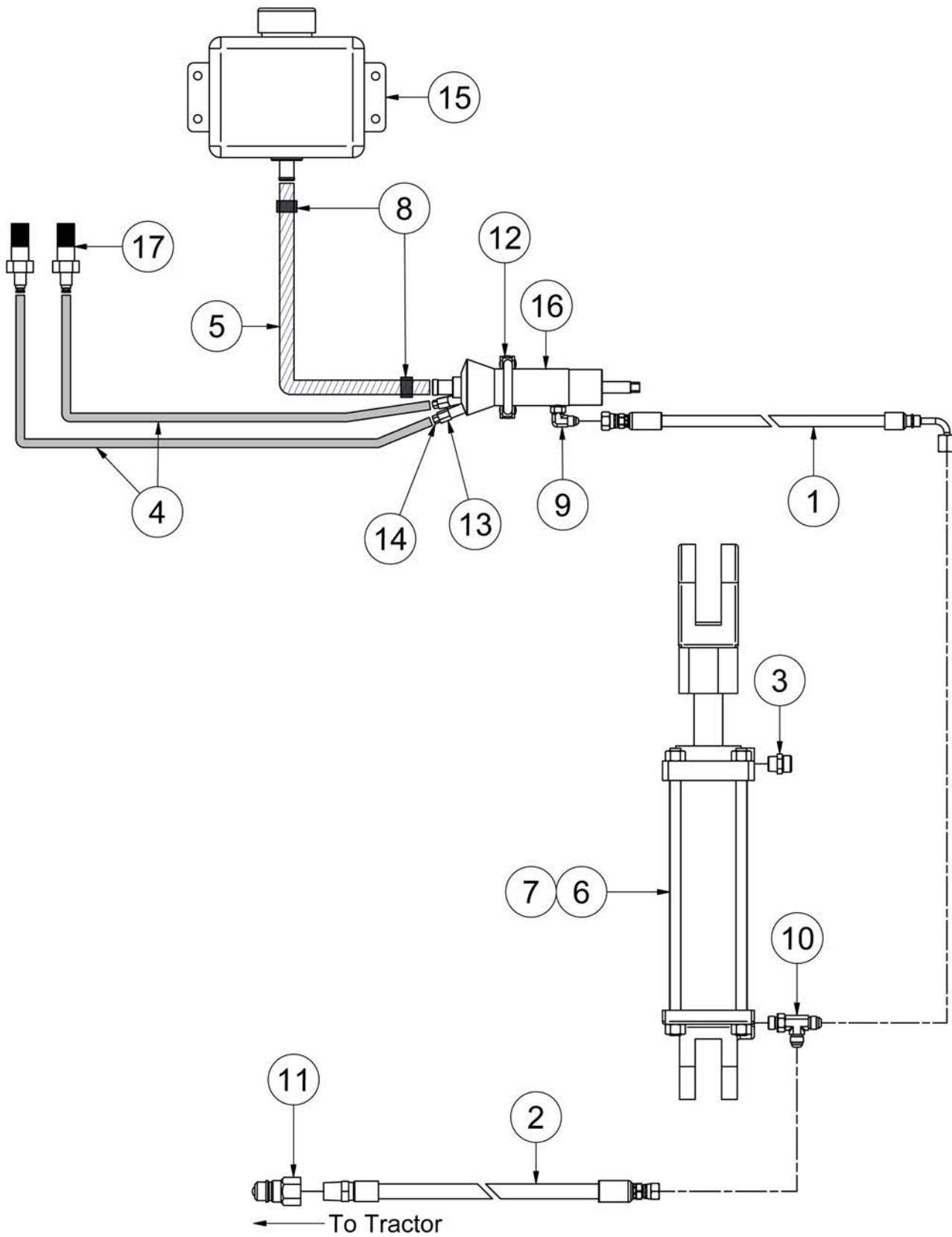

Hydraulic Layout

ITEM	QTY	PART NUMBER	DESCRIPTION
1	1	28294	Hose - HH64 - 4ATI(6FJXH90S,4FJXH)HCL 64"
2	1	28597	Hose - HH72 - 6AT1(8MP,6FJXH) HCL 72"
3	1	28598	Air Breather
4	2	37710	1/8 Oiler Line
5	1	37711	5/8 Braided Oil Hose
6	1	CYL 30008-2	3 x 8 Stroke
7	1	SK AGU301250-10	Seal Kit F/Tail Gate (Cylinder 3.0")
8	1	HC 20	#20 Gear Clamp (.75-1.75)
9	1	HF 6801-4-4	Hydraulic Fitting - 90° O-Ring to JIC
10	1	HF 6804-6-6-6	Hyd Fitting - Male JIC - Male ORB Tee
11	1	HF 8010-4	Quickcoupler 1/2" Male Tip
12	1	MC 1 1/2	Muffler Clamp 1 1/2" Pipe (MC7112)
13	1	PP-01026	Sleeve Nut
14	1	PP-01027	5/32 Ferrule
15	1	PP00072	Oil Reservoir - 2 Quart
16	1	PP00087	Lube Minder - 2 Port Pump
17	2	PP00088	Oiler Brush

Section 9: Driveshafts

PP00338 - Slip Clutch Drive Shaft

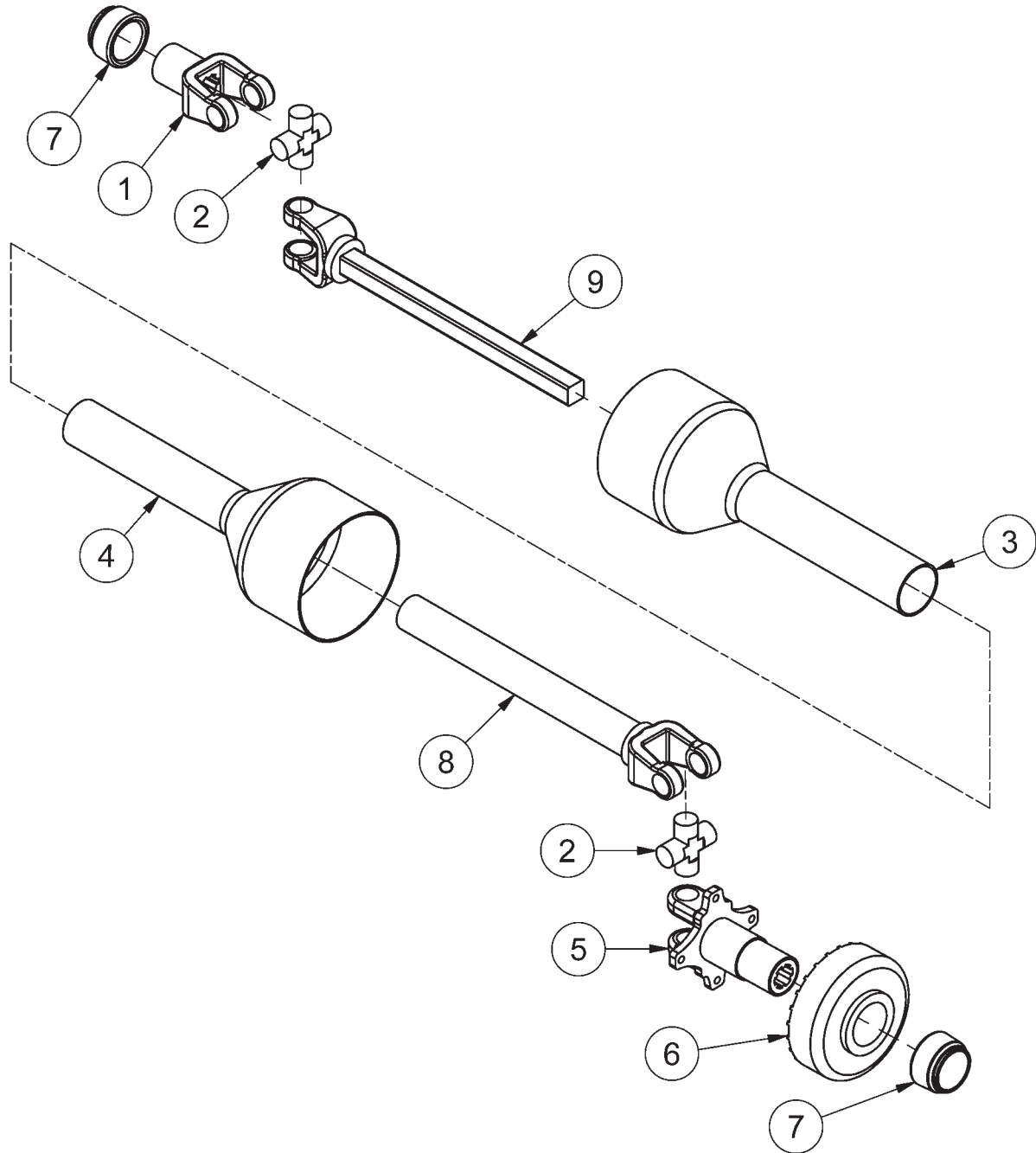

ITEM	QTY	PART NUMBER	DESCRIPTION
1	1	PP-00963	Auto lock yoke ass/35031-1015
2	2	PP-00964	35e cross and bearing kit/03-15303
3	1	PP-00967	Outer guard/97-24673
4	1	PP-00968	Inner guard/96-24673
5	1	PP-00969	35s clutch yoke/38-20015
6	1	PP-00970	Over-running friction clutch pack/38-51014
7	2	PP-00984	Auto lock repair kit/26-15120
8	1	PP-00985	Yoke, tube and slip sleeve/98-24673
9	1	PP-00986	Yoke and shaft/99-24673

PP-00339 - PTO Drive Shaft

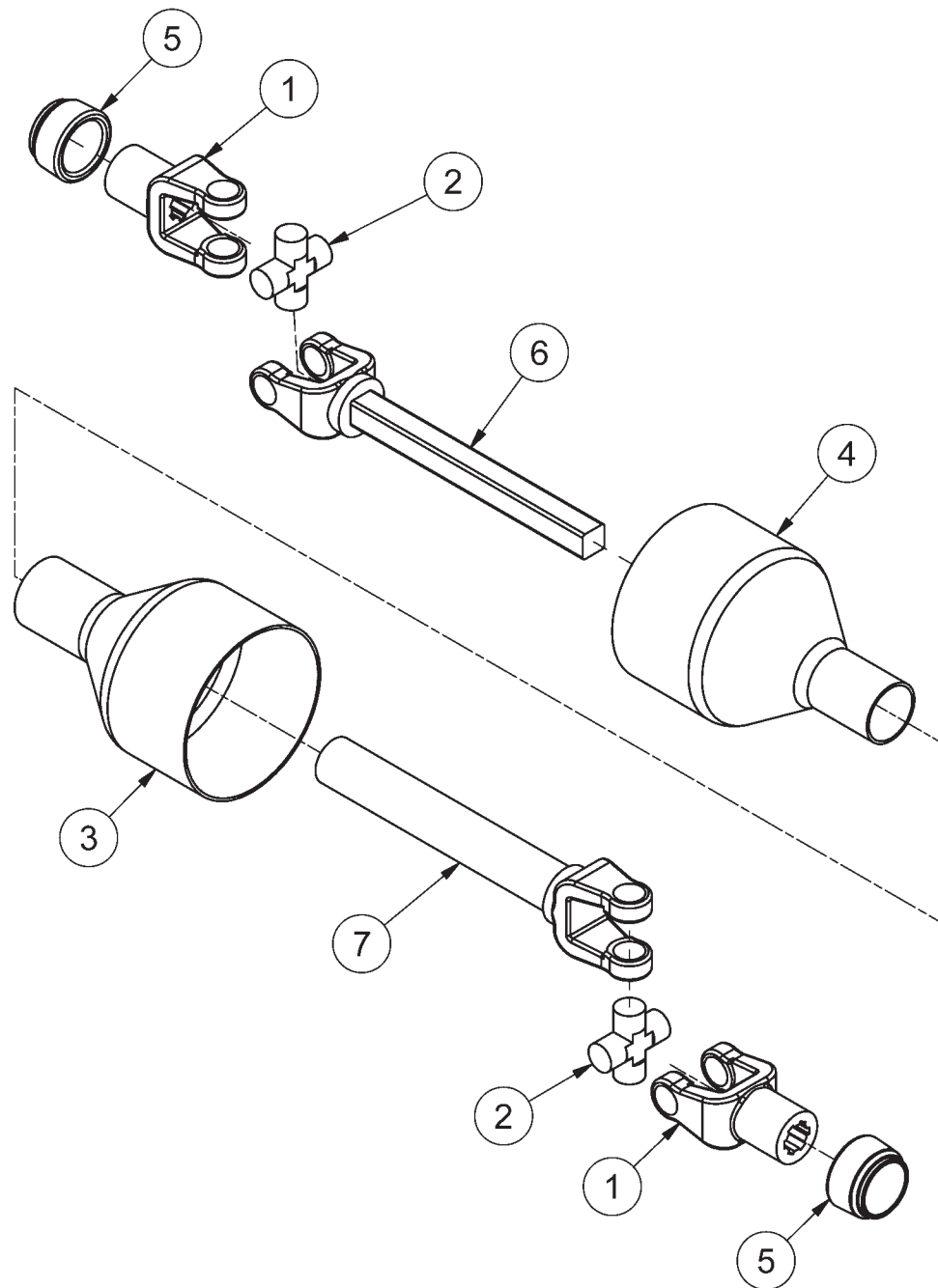

ITEM	QTY	PART NUMBER	DESCRIPTION
1	2	PP-00963	Auto lock yoke ass/35031-1015
2	2	PP-00964	35e cross and bearing kit/03-15303
3	1	PP-00965	Outer guard/97-24672
4	1	PP-00966	Inner guard/96-24672
5	2	PP-00984	Auto lock repair kit/26-15120
6	1	PP-00997	Yoke and shaft/99-24672
7	1	PP-00998	Yoke tube and slip sleeve/98-24672

PP00836 - HC7500 Cross Drive Shaft

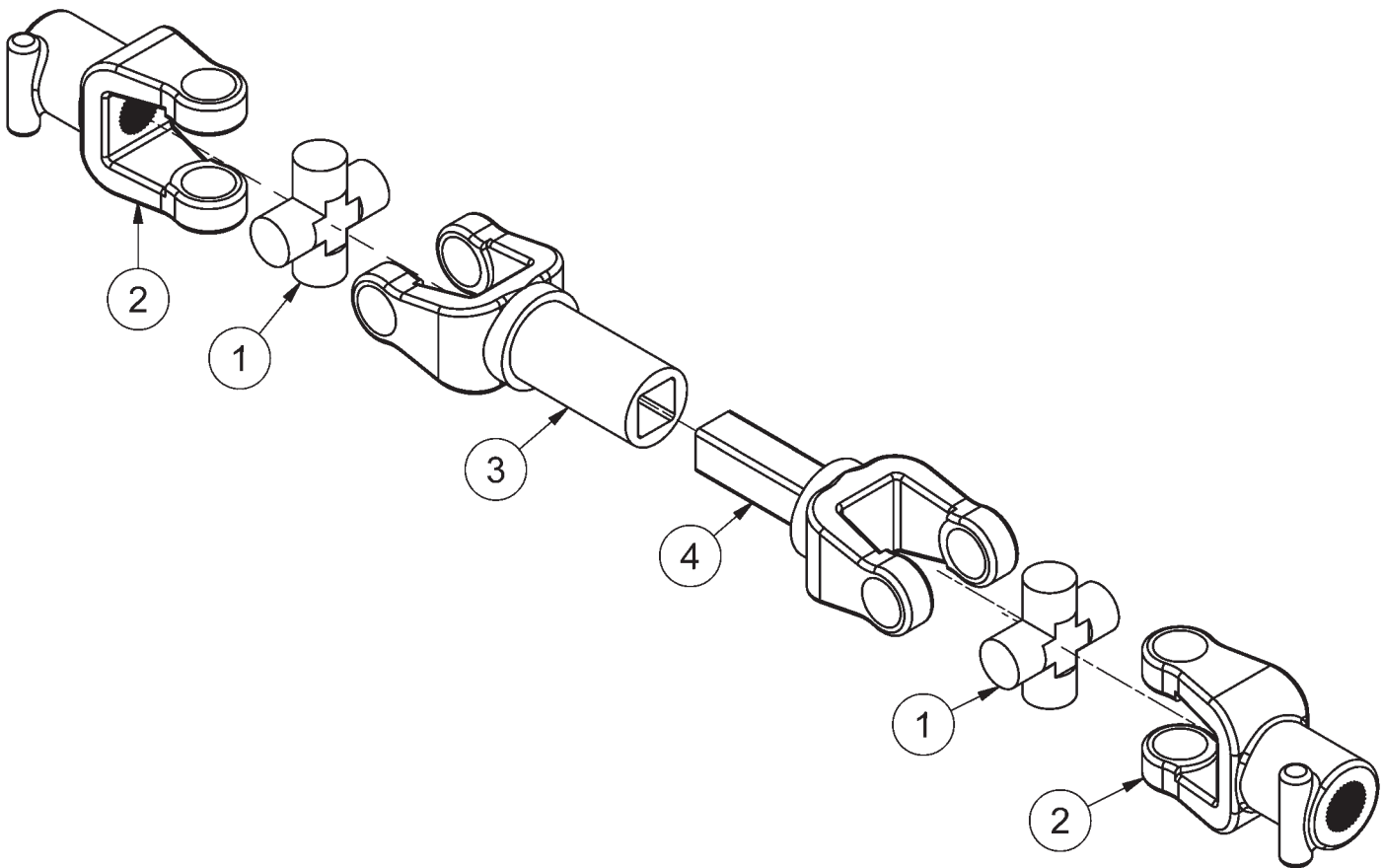

ITEM	QTY	PART NUMBER	DESCRIPTION
1	2	PP-00964	35e cross and bearing kit/03-15303
2	2	PP-00971	Yoke/35190-1001
3	1	PP-01001	Yoke tube and slip sleeve/98-24674
4	1	PP-01002	Yoke and shaft/99-24674

PP00837 - HC9500 Cross Drive Shaft

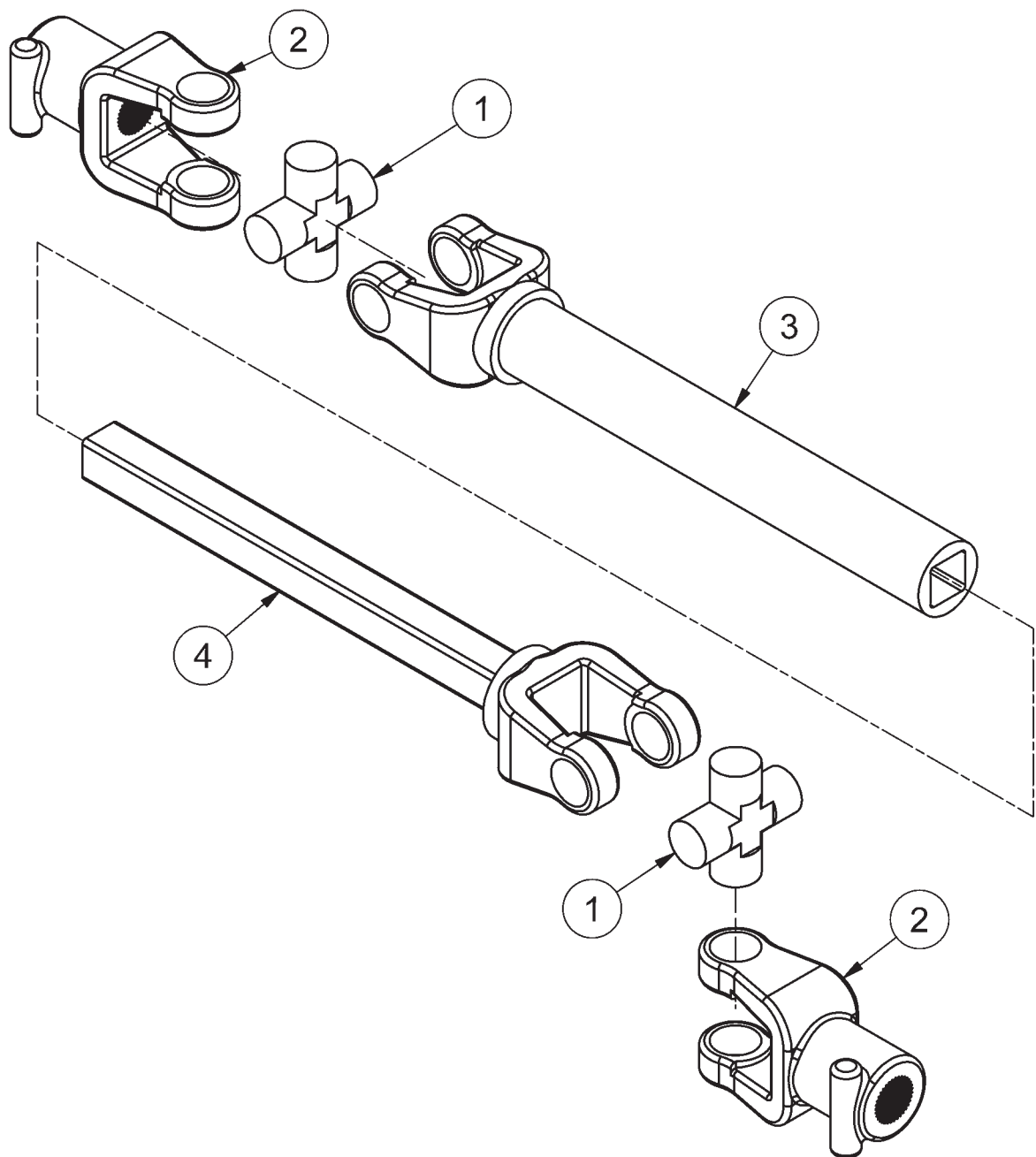

ITEM	QTY	PART NUMBER	DESCRIPTION
1	2	PP-00964	35e cross and bearing kit/03-15303
2	2	PP-00971	Yoke/35190-1001
3	1	PP-00999	Yoke tube and slip sleeve/98-24675
4	1	PP-01000	Yoke and shaft/99-24675

Section 10: Options

HCSK7500T - Spinner Kit

The HCSK7500T - Optional Spinner Kit is designed to further improve hay drying time by means of spreading out the material as it exits the Accelerator rollers.

Spinner Kit Terminology

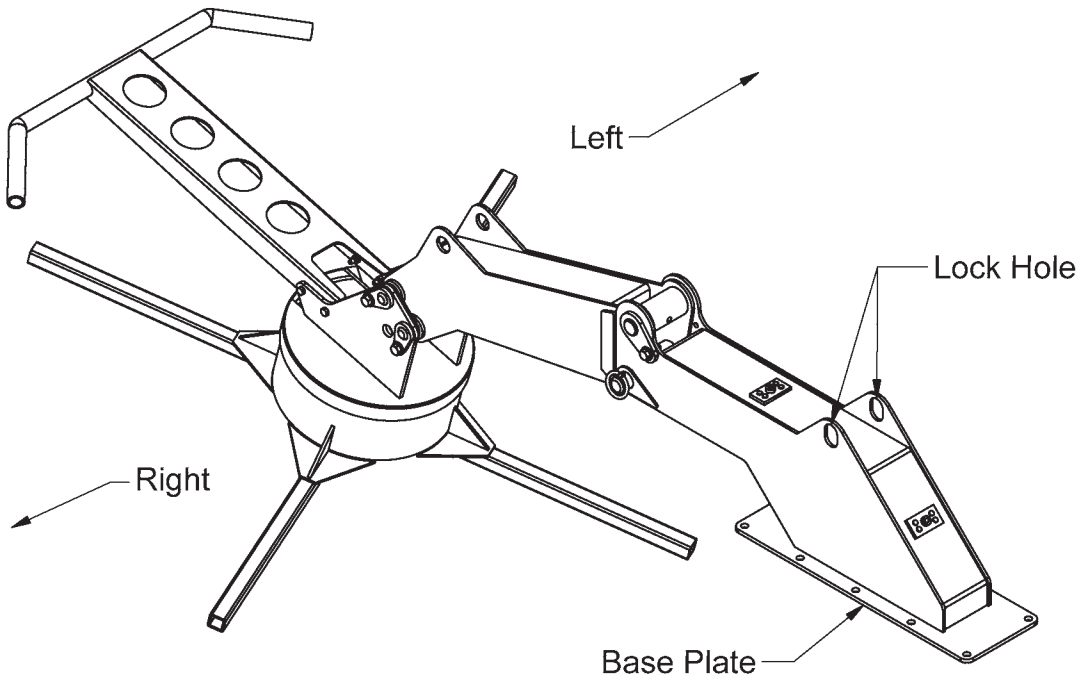

Spinner Kit Components

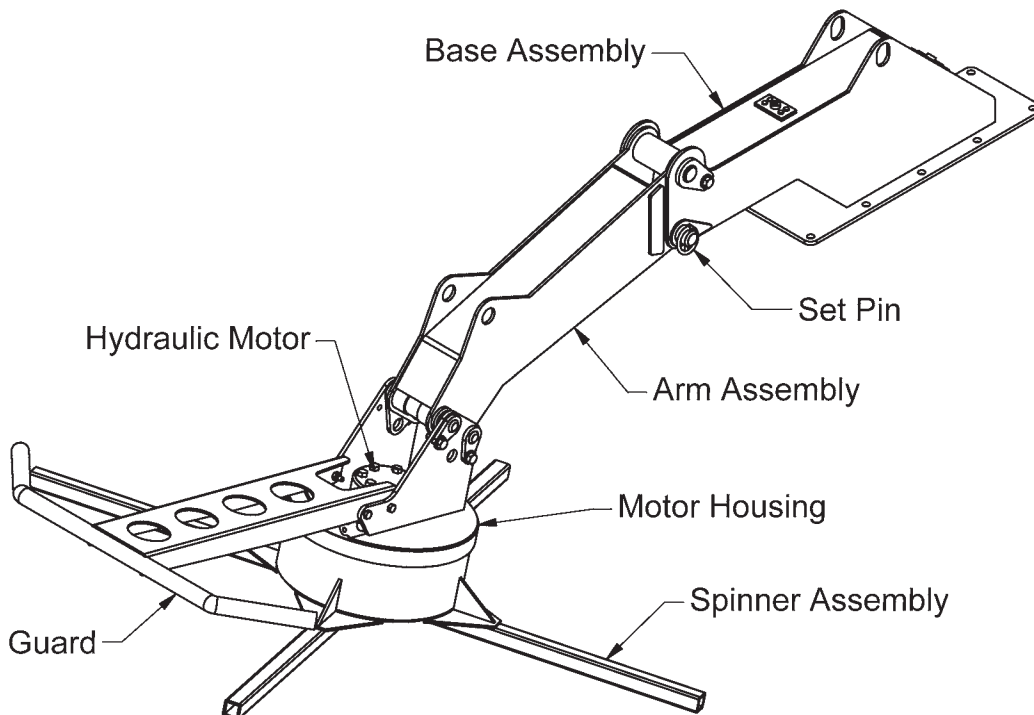

HCSK7500T - Spinner Kit Installation

The HCSK7500T Spinner Kit option should take an hour to install.

These mounting instructions will help you mount your Spreader Kit onto the Accelerator in an easy and safe manner. Follow the instructions in the given order or difficulties may arise.



WARNING: Each HC-SK-0-01 Spreader Assembly weighs ~120lbs (54.5 kg). A second person or mechanical hoist is highly recommended to lift each spinner kit assembly onto the Accelerator.

1. Align the holes on the Spreader Kit base plate with the holes on the top of the Accelerator, and secure with 1/4 x 2-1/4" bolts and lock nuts as shown on [pg.10-5](#).
2. Drill and bolt relief valve assembly **(A)** to Accelerator using 3/8 x 1.5" bolt and lock nuts.
3. Drill and bolt hose clamps **(B)** using 5/16 x 2.25" bolt and lock nut.
4. Install hoses as shown on [Spinner Kit - Hydraulic Layout, pg.10-7](#).

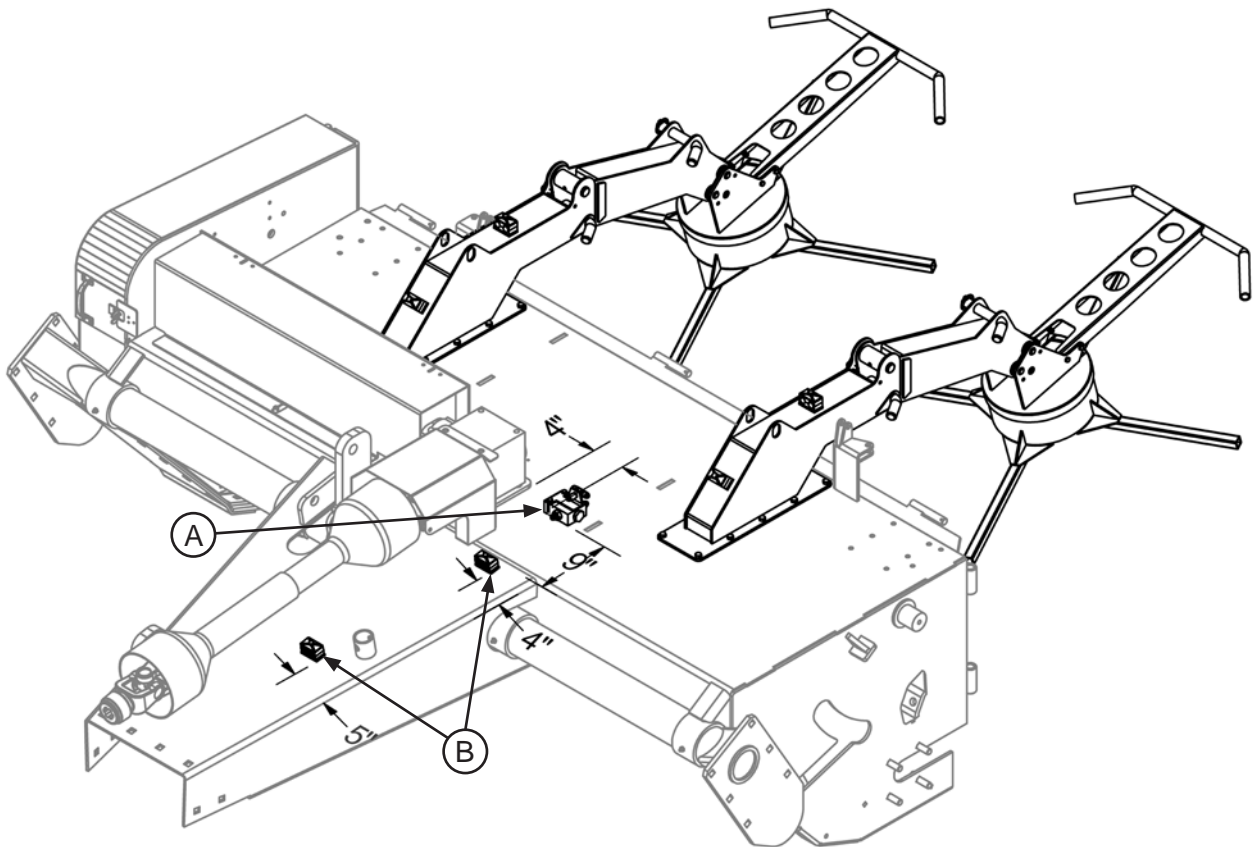

Spinner Kit Setup

If your spinner kit is in the storage position, as shown below, follow these instructions to ready for use:

1. Remove pins **(A)** from locking holes.
2. Pivot arm and spinner assembly towards rear of machine.

WARNING: Check that no hoses are pinched.

3. Lock pins into operating position holes.

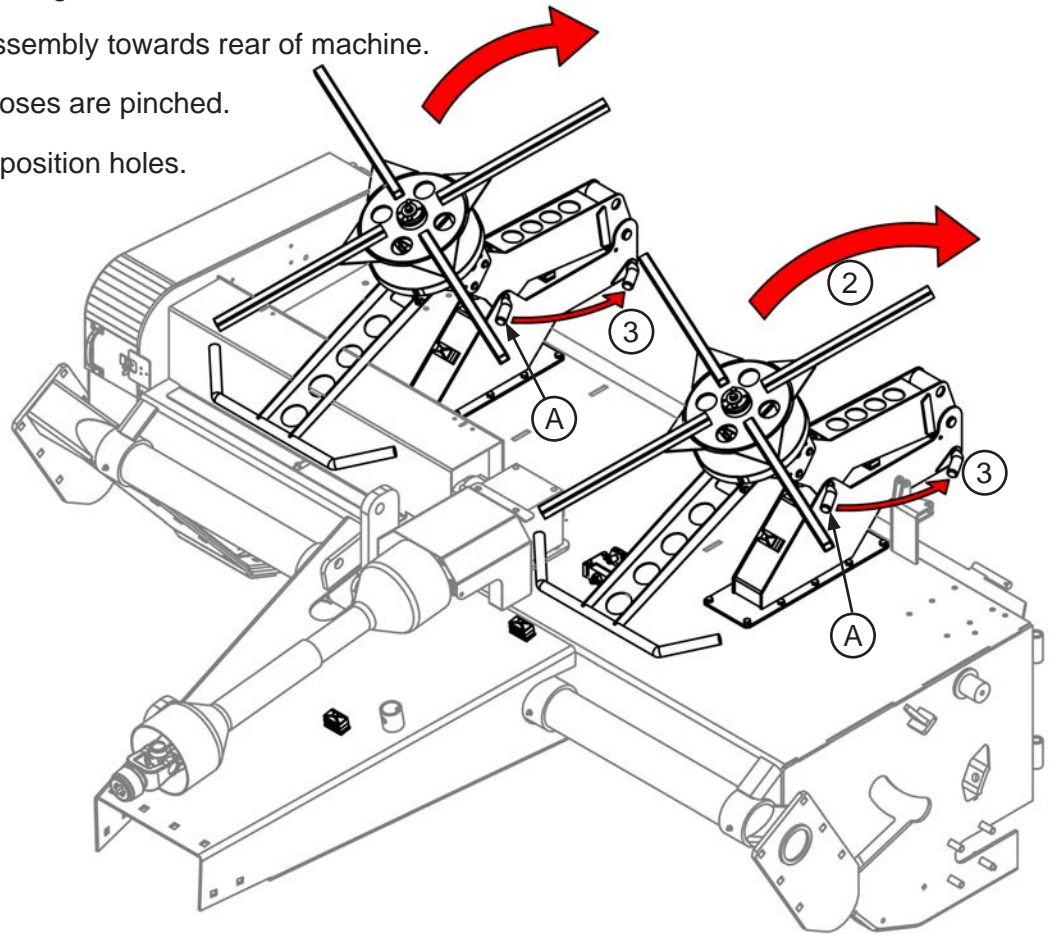

Spinner Adjustment

The Spreader Kit fan angle can be adjusted to change the spread angle.

Remove one of the two pins **(A)** and move to other location.

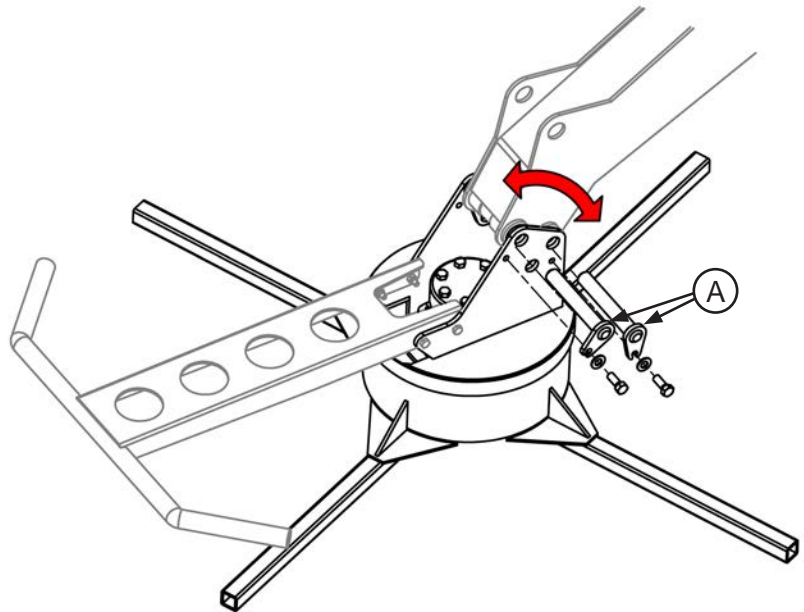

Spinner Operation

Connect hydraulic quick couplers to power unit. Pressurize system and adjust flow rate to control spinner speed. Before transporting Accelerator with Spinner kit option, lift and lock spinners into storage position.

Spinner Kit Grease Points

Grease the fittings with 3 strokes every 100 operating hours.

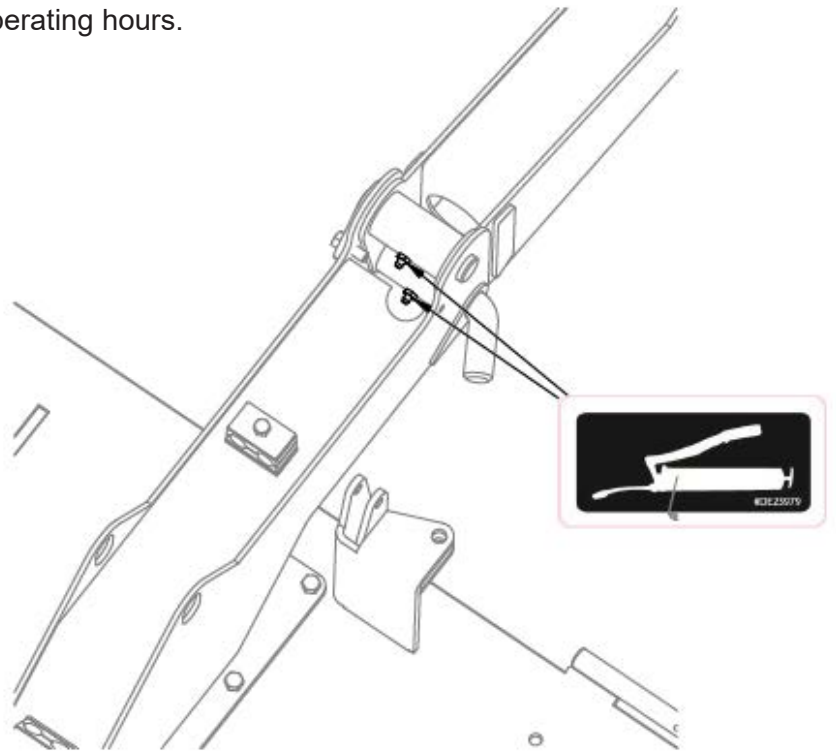

Spinner Kit Maintenance

Before operating spinner option, ensure all hardware is tight and hydraulic fittings and hoses are in good working order.

Remove any crop material before winterizing.

Spinner Kit Troubleshooting

Problem: Can not get desired spinner speed.

Solution 1: Check all connections for restrictions.

Solution 2: Make sure the tractor has 15 gal/min or more oil flow capacity.

Problem: Crop material does not spread out in a consistent pattern.

Solution: Readjust top deflector on accelerator and/or readjust spinner angle.

Problem: Crop material wraps around spinners.

Solution: Re-adjust spinner angle.

HCSK7500T - Spinner Kit

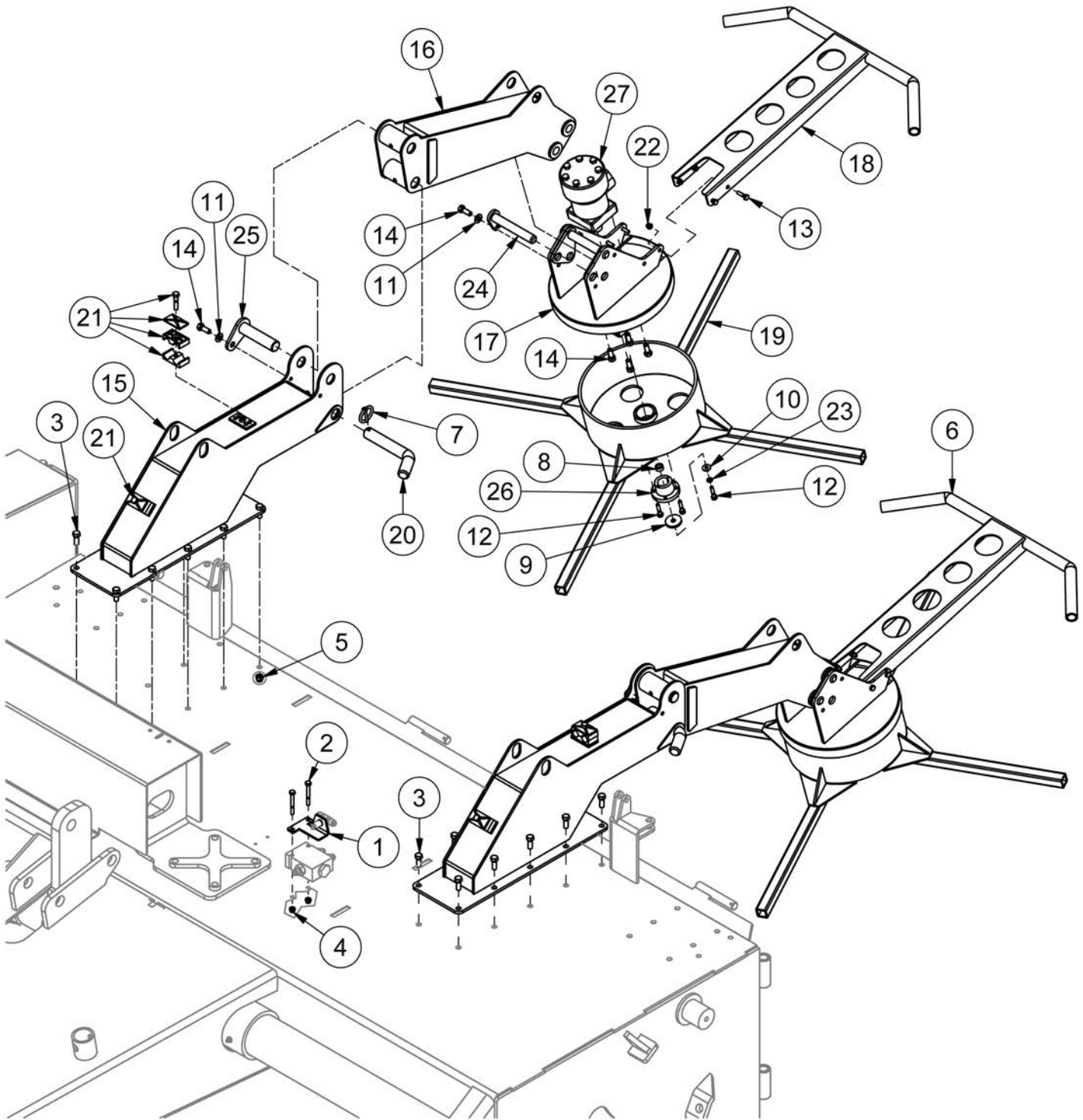

HCSK7500T - Spinner Kit

ITEM	QTY	PART NUMBER	DESCRIPTION	NOTE
1	1	40709	HRP 0.135 in	
2	2	HB1/4-20X2.25Z5	Hex Bolt 1/4-20x2 1/4 Grade 5 Zinc Plated Hex Cap Screw	
3	20	HB3/8-16X1Z5	Hex Bolt 3/8-16x1 Grade 5 Zinc Plated Hex Cap Screw	
4	2	LN1/4-20NCZ5	LN 1/4-20 Zinc Plated Nylon Insert Lock Nut	
5	20	LN3/8-16NCZ5	LN 3/8-16 Zinc Plated Nylon Insert Lock Nut	
6	2	HC-SK-0-01	Spreader Kit	Items 7-27
7	1	25680	Linch Pin 3/16 X 1.5	
8	1	36066	Spacer	
9	1	36067	Washer	
10	1	FW 1/4	Flatwasher - 1/4" Zinc Plated USS	
11	3	FW 3/8	Flatwasher - 3/8" Zinc Plated USS	
12	3	HB1/4-20X1.25Z5	Hex Bolt 1/4-20x1 1/4 Gr 5 Zinc Plated Hex Cap Screw	
13	4	HB1/4-20X1Z5	Hex Bolt 1/4-20x1 Gr 5 Zinc Plated Hex Cap Screw	
14	7	HB3/8-16X1Z5	Hex Bolt 3/8-16x1 Gr 5 Zinc Plated Hex Cap Screw	
15	1	HC-SK-0-02	Base Assembly	
16	1	HC-SK-0-03	Arm Assembly	
17	1	HC-SK-0-04	Motor Housing	
18	1	HC-SK-0-05	Guard	
19	1	HC-SK-0-06	Spinner	
20	1	HC-SK-023	Pin	
21	2	LA-HOSE CLAMP	Hose Clamp - 3/8"	
22	4	LN1/4-20NCZ5	LN 1/4-20 Zinc Plated Nylon Insert Lock Nut	
23	1	LW 1/4	LW - 1/4" Zinc Plated Medium Split	
24	2	PA-00750-05375-01-01	Pin	
25	1	PA-01000-04500-01-01	4.5" Pin	
26	1	PP00314	Taper Lock Bushing 1"	
27	1	PP00742	Hydraulic Motor, MS 80	

HCSK7500T Spinner Kit - Hydraulic Layout

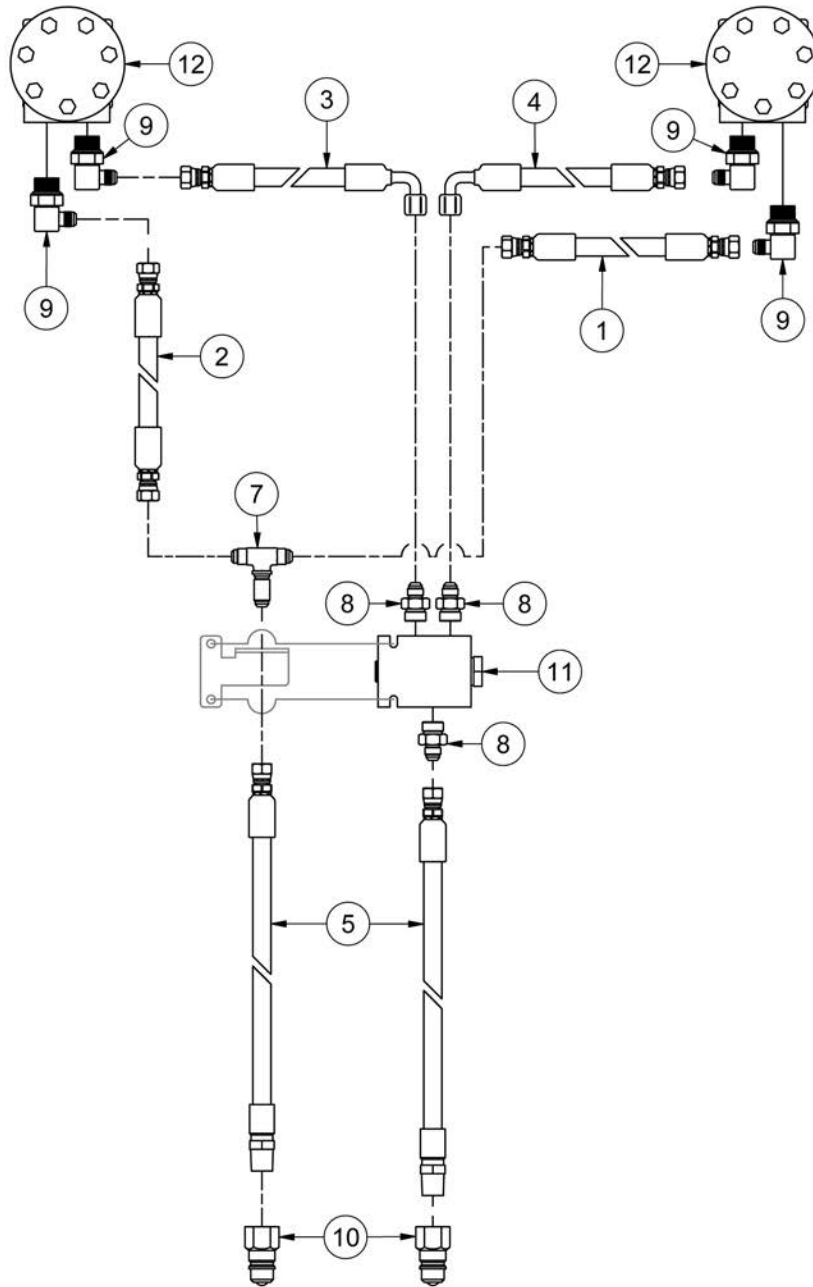

ITEM	QTY	PART NUMBER	DESCRIPTION
1	1	36233	Hose - HH74-6AT1(6FJXH,6FJX) HCL 74"
2	1	40705	Hose - HH86" 6AT1 (6FJXH-6FJXH) HCL 86"
3	1	40706	Hose - HH86" 6AT1 (6FJXH-6FJX90L) HCL 86"
4	1	40707	Hose - HH74" 6AT1 (6FJXH-6FJX90L) HCL 74"
5	2	40708	Hose - HH132" - 6AT1(8MP,6FJXH) HCL 132"
6	1	40709	Flow Divider Mount
7	1	HF 2703LN-6-6-6	Bulkhead Tee Fitting
8	3	HF 6400-6-8	Hydraulic Adaptor Fitting
9	4	HF 6801-6-10	Hydraulic Elbow Adaptor
10	2	HF 8010-4	1/2" Male Quick Coupler
11	1	LA-FDV40	50-50 Flow Divider
12	2	PP00742	Hydraulic Motor, MS 80





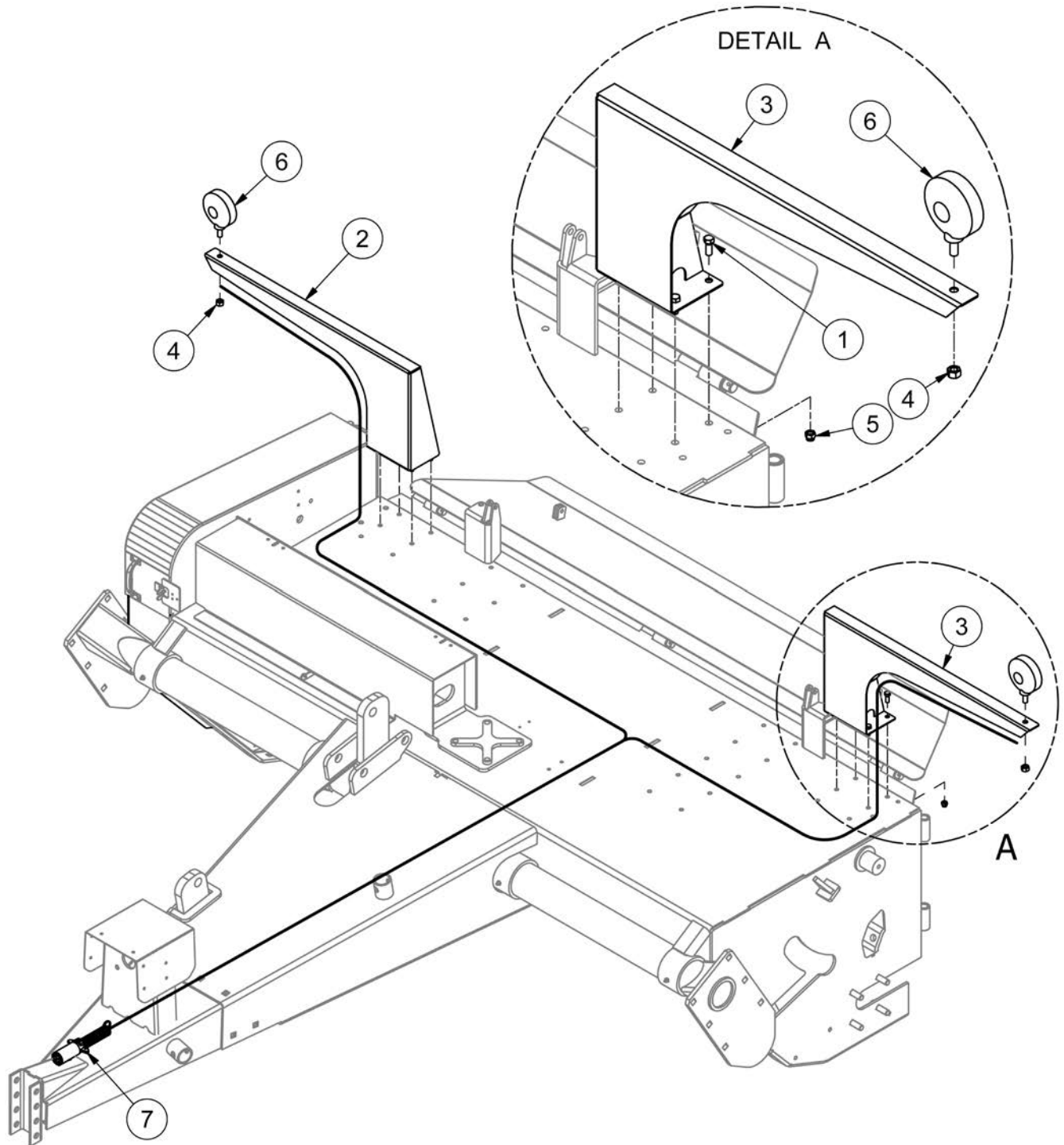





HCLK7500 / HCLK9500 - Light Kit

Improve the visibility of your Accelerator with running lights.

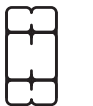

ITEM	QTY	PART NUMBER	DESCRIPTION
1	8	HB3/8-16X1Z5	Hex Bolt 3/8-16x1 Grade 5 Zinc Plated Hex Cap Screw
2	1	HC-A27	Right Light Arm
3	1	HC-A27_MIR	Left Light Arm
4	2	HN1/2-13CZ5	Hex Nut 1/2"-13 Grade 5 Zinc Plated Finished
5	8	LN3/8-16NCZ5	LN 3/8-16 Zinc Plated Nylon Insert Lock Nut
6	2	PP00770	Amber Light for Accelerator Light Kits
7	1	TL550-200-117	7 Pin Plug

Torque Values - Imperial

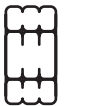
SAE Grade and Head Markings	NO MARK 1 or 2 ^b 	5 	5.1 	5.2 	8 	8.2 	
SAE Grade and Nut Markings	NO MARK 2 	5 			8 		

Size	Grade 1				Grade 2 ^b				Grade 5, 5.1, or 5.2				Grade 8 or 8.2			
	Lubricated ^a		Dry ^a		Lubricated ^a		Dry ^a		Lubricated ^a		Dry ^a		Lubricated ^a		Dry ^a	
	N-m	lb-ft	N-m	lb-ft	N-m	lb-ft	N-m	lb-ft	N-m	lb-ft	N-m	lb-ft	N-m	lb-ft	N-m	lb-ft
1/4	3.7	2.8	4.7	3.5	6	4.5	7.5	5.5	9.5	7	12	9	13.5	10	17	12.5
5/16	7.7	5.5	10	7	12	9	15	11	20	15	25	18	28	21	35	26
3/8	14	10	17	13	22	16	27	20	35	26	44	33	50	36	63	46
7/16	22	16	28	20	35	26	44	32	55	41	70	52	80	58	100	75
1/2	33	25	42	31	53	39	67	50	85	63	110	80	120	90	150	115
9/16	48	36	60	45	75	56	95	70	125	90	155	115	175	130	225	160
5/8	67	50	85	62	105	78	135	100	170	125	215	160	240	175	300	225
3/4	120	87	150	110	190	140	240	175	300	225	375	280	425	310	550	400
7/8	190	140	240	175	190	140	240	175	490	360	625	450	700	500	875	650
1	290	210	360	270	290	210	360	270	725	540	925	675	1050	750	1300	975
1-1/8	400	300	510	375	400	300	510	375	900	675	1150	850	1450	1075	1850	1350
1-1/4	570	425	725	530	570	425	725	530	1300	950	1650	1200	2050	1500	2600	1950
1-3/8	750	550	950	700	750	550	950	700	1700	1250	2150	1550	2700	2000	3400	2550
1-1/2	1000	725	1250	925	990	725	1250	930	2250	1650	2850	2100	3600	2650	4550	3350

DO NOT use these values if a different torque value or tightening procedure is given for a specific application. Torque values listed are for general use only. Check tightness of fasteners periodically.

Shear bolts are designed to fail under predetermined loads. Always replace shear bolts with identical grade.

Fasteners should be replaced with the same or higher grade. If higher grade fasteners are used, these should only be tightened to the strength of the original.

Make sure fasteners threads are clean and that you properly start thread engagement. This will prevent

them from failing when tightening.

Tighten plastic insert or crimped steel-type lock nuts to approximately 50 percent of the dry torque shown in the chart, applied to the nut, not to the bolt head. Tighten toothed or serrated-type lock nuts to the full torque value.

^a "Lubricated" means coated with a lubricant such as engine oil, or fasteners with phosphate and oil coatings. "Dry" means plain or zinc plated without any lubrication.

^b Grade 2 applies for hex cap screws (not hex bolts) up to 152 mm (6-in.) long. Grade 1 applies for hex cap screws over 152 mm (6-in.) long, and for all other types of bolts and screws of any length.

Torque Values - Metric

Property Class and Head Markings	4.8		8.8		9.8		10.9		12.9	
Property Class and Nut Markings	5		10		10		10		12	

Size	Class 4.8				Class 8.8 or 9.8				Class 10.9				Class 12.9			
	Lubricated ^a		Dry ^a		Lubricated ^a		Dry ^a		Lubricated ^a		Dry ^a		Lubricated ^a		Dry ^a	
	N-m	lb-ft	N-m	lb-ft	N-m	lb-ft	N-m	lb-ft	N-m	lb-ft	N-m	lb-ft	N-m	lb-ft	N-m	lb-ft
M6	4.8	3.5	6	4.5	9	6.5	11	8.5	13	9.5	17	12	15	11.5	19	14.5
M8	12	8.5	15	11	22	16	28	20	32	24	40	30	37	28	47	35
M10	23	17	29	21	43	32	55	40	63	47	80	60	75	55	95	70
M12	40	29	50	37	75	55	95	70	110	80	140	105	130	95	165	120
M14	63	47	80	60	120	88	150	110	175	130	225	165	205	150	260	190
M16	100	73	125	92	190	140	240	175	275	200	350	255	320	240	400	300
M18	135	100	175	125	260	195	330	250	375	275	475	350	440	325	560	410
M20	190	140	240	180	375	275	475	350	530	400	675	500	625	460	800	580
M22	260	190	330	250	510	375	650	475	725	540	925	675	850	625	1075	800
M24	330	250	425	310	650	475	825	600	925	675	1150	850	1075	800	1350	1000
M27	490	360	625	450	950	700	1200	875	1350	1000	1700	1250	1600	1150	2000	1500
M30	675	490	850	625	1300	950	1650	1200	1850	1350	2300	1700	2150	1600	2700	2000
M33	900	675	1150	850	1750	1300	2200	1650	2500	1850	3150	2350	2900	2150	3700	2750
M36	1150	850	1450	1075	2250	1650	2850	2100	3200	2350	4050	3000	3750	2750	4750	3500

DO NOT use these values if a different torque value or tightening procedure is given for a specific application. Torque values listed are for general use only. Check tightness of fasteners periodically.

Shear bolts are designed to fail under predetermined loads. Always replace shear bolts with identical property class.

Fasteners should be replaced with the same or higher property class. If higher property class fasteners are used, these should only be tightened to the strength of the original.

Make sure fasteners threads are clean and that you

properly start thread engagement. This will prevent them from failing when tightening.

Tighten plastic insert or crimped steel-type lock nuts to approximately 50 percent of the dry torque shown in the chart, applied to the nut, not to the bolt head. Tighten toothed or serrated-type lock nuts to the full torque value.

a "Lubricated" means coated with a lubricant such as engine oil, or fasteners with phosphate and oil coatings. "Dry" means plain or zinc plated without any lubrication.

Index

Operator's Manual	I
Improvements	I
Serial Number	I
Warranty and Limitation of Liability	I
Section 1: General Information1-1
Accelerator Initial Setup1-2
Principle Components1-1
Specifications1-3
Terminology : Accelerator1-1
Terminology : Accelerator Locations1-1
Tire Ratings1-4
Tractor Requirements1-4
Section 2: Safety2-1
Hydraulic Safety2-2
ISO Safety Decal Locations2-4
ISO Safety Decals2-5
Maintenance Safety2-2
Model Decal Locations2-6
Model Decals2-7
Safety Guidelines2-1
Safety Signal Words / Safety Messages2-1
Safety Signs2-3
Tire Safety2-3
Transport Safety2-3
Section 3: Transportation3-1
Accelerator Hook up to Power Unit3-1
Transport Lock3-2
Section 4: Adjustments4-1
Deflectors4-1
Roller Chain Tensioning4-3
Roller Tensioning - SN 22HCT101 to Current4-2
Roller Tensioning - Up to SN 22HCT1014-1
Section 5: Lubrication5-1
Grease Point - Lifting Pivot5-2
Grease Point - Pillow Block Bearing5-2
Grease Point - PTO Knuckles5-1
Grease Points5-1
Section 5: Operation5-1
Section 6: Maintenance6-1
Daily Maintenance6-2
End of Season Service6-2
Friction Clutch Maintenance6-1
Preseason Service6-2
Section 7: Troubleshooting7-1

Section 8: Parts Breakdowns & Lists8-1
Discharge Shields8-8
Driveline8-6
Hydraulic Layout	8-18
Left Side Panel	8-10
Main Frame Components8-2
Right Side Chain	8-14
Right Side Shields	8-12
Rollers8-4
Rosta Tensioner - Chain Oiler	8-16
Section 9: Driveshafts9-1
PP00338 - Slip Clutch Drive Shaft9-1
PP-00339 - PTO Drive Shaft9-2
PP00836 - HC7500 Cross Drive Shaft9-3
PP00837 - HC9500 Cross Drive Shaft9-4
Section 10: Options	10-1
HCLK7500 / HCLK9500 - Light Kit	10-8
HCSK7500T - Spinner Kit	10-1
HCSK7500T - Spinner Kit	10-5
HCSK7500T Spinner Kit - Hydraulic Layout	10-7
HCSK7500T - Spinner Kit Installation	10-2
Spinner Adjustment	10-3
Spinner Kit Components	10-1
Spinner Kit Grease Points	10-4
Spinner Kit Maintenance	10-4
Spinner Kit Setup	10-3
Spinner Kit Terminology	10-1
Spinner Kit Troubleshooting	10-4
Spinner Operation	10-3
Torque Values - Imperial	IV
Torque Values - Metric	V



Scan with smartphone to
download latest manual.



WARNING

The paint used on this product contains chemicals known in the state of California to cause cancer, birth defects, or other reproductive harm.

TUBE•LINE™